

SIGN POST	BASE POST
2-1/4" 12Gauge	2-1/4" with 2-1/2" Sleeve 12Gauge or 3" 7Gauge
2-1/4" & 2-1/2" 12Gauge	
2-3/16" 10Gauge	
2-3/16" & 2-1/2" 10Gauge	

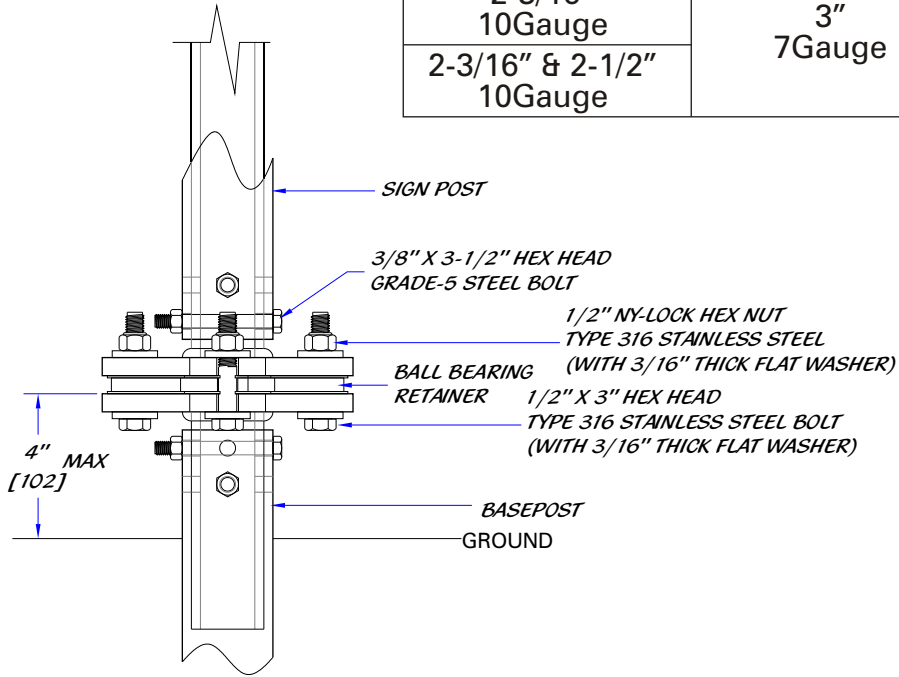
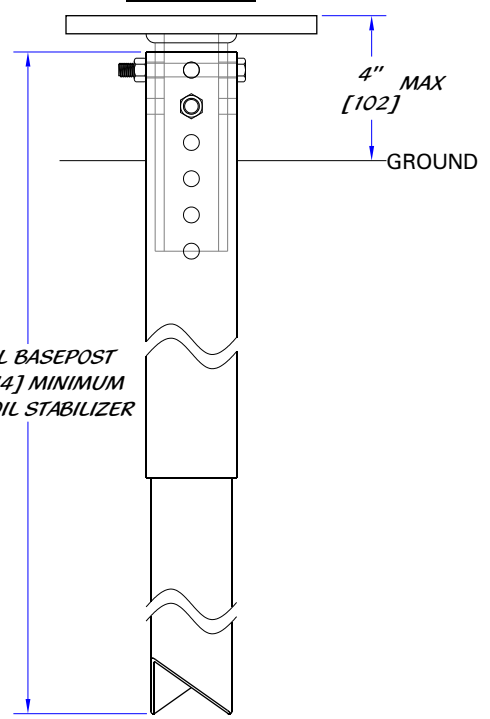
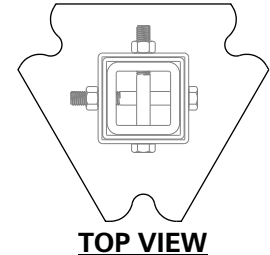

DETAIL-B BASE POST

[ALL DIMENSIONS INSIDE BRACKET ARE IN MILLIMETERS]

ULTI-MATE SQUARE TUBE SLIPBASE



ULTIMATE HIGHWAY PRODUCTS, INC.
P.O. BOX 7 - STANTON, CA 90680
800-730-4939 Fax 815-462-9562
Web Page <http://uhp-inc.com>

Sheet No:	Date: