

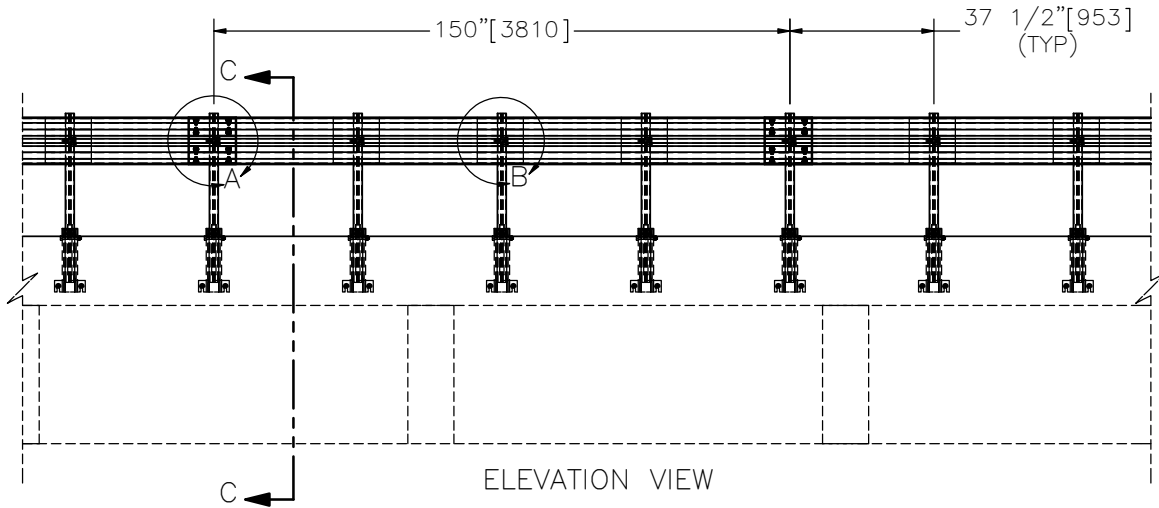

PLAN VIEW

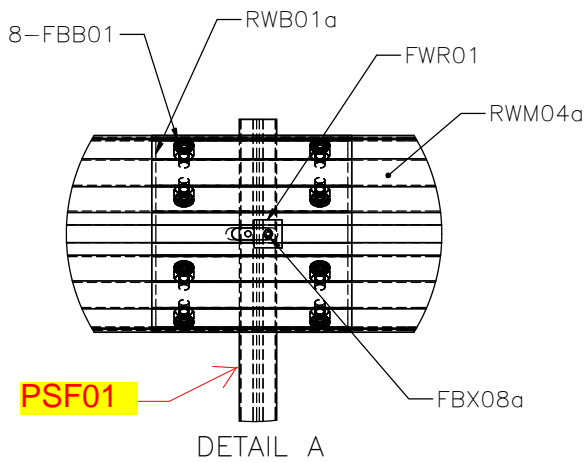

ELEVATION VIEW



DETAIL A

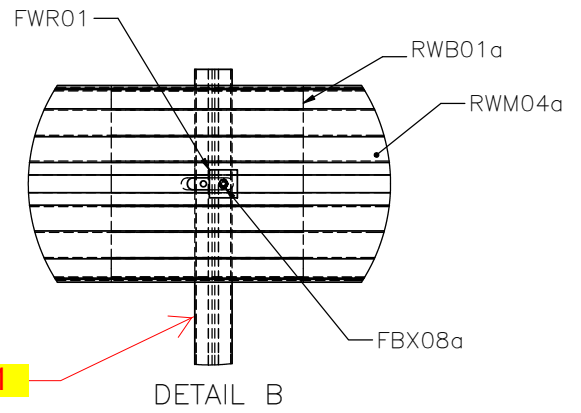

DETAIL B

TOP-MOUNTED WEAK-POST GUARDRAIL ATTACHED TO CULVERT



SGR52

SHEET NO.

DATE:

1 of 7

5/28/2015

INTENDED USE

The Top-Mounted Weak-Post Guardrail Attached to Culvert is designed as a treatment to continue W-beam guardrail systems across large box culverts. It is compatible with the Midwest Guardrail System (MGS) with or without blockouts (SGR20a-c or SGR41) such that an approach transition would not be required between the two barriers. The Top-Mounted Weak-Post Guardrail Attached to Culvert is an adaptation of the MGS Bridge Rail (SBO02c) with only the socket length and attachment hardware changing. All post and rail components are identical to the original MGS Bridge Rail (SBO02c). The Top-Mounted Weak-Post Guardrail Attached to Culvert is TL-3 accepted, and is accepted according to the Manual for Assessing Safety Hardware (MASH) safety performance criteria.

The Top-Mounted Weak-Post Guardrail Attached to Culvert is one of two configurations for the Weak-Post Guardrail Attached to Culvert. The other configuration is a Side-Mounted Weak-Post Guardrail Attached to Culvert (SGR53).

A stiffness transition between the new guardrail attached to culvert system and adjacent MGS installation (SGR20a-c or SGR41) is unnecessary. A 75-in. [1905] spacing is recommended between the last S3x5.7 (S76x8.5) culvert post (PSF01) and the first guardrail post of the adjacent MGS installation. The adjacent MGS may be either blocked or non-blocked (SGR20a-c or SGR41).

COMPONENTS

Unit Length = 150" [3810]

DESIGNATOR	COMPONENT	NUMBER
PSF01	S3x5.7 by 44" long Post and Standoff	4
RWM04a	12'-6" W-Beam MGS Section 1/2 Post Spacing	1
RWB01a	W-Beam Backup Plate	4
FBX08a	Hex Bolt 5/16"-18x1 1/4" and Nut	4
FWR01	1 3/4"x1 3/4"x1/8" Square Guardrail Washer	4
FBB01	5/8" Dia., 1 1/2" Long Guardrail Bolt and Nut	8
FBX16a	Hex Bolt 5/8"-11x5 1/4" and Nut	4
-----	Top-Mounted Bracket Assembly	4
FWC30a	1 1/8" Plain Round Washer	4
FWC12a	1/2" Plain Round Washer	8
FRR28	1 1/8" Dia., 13" Long Threaded Rod	4
FNX28a	1 1/8" Dia. Hex Nut	4
FRR12b	1/2" Dia., 7" Long Threaded Rod	8
FNX12a	1/2" Dia. Hex Nut	8

ELIGIBILITY

FHWA Eligibility is being pursued.

TOP-MOUNTED WEAK-POST GUARDRAIL ATTACHED TO CULVERT



SGR52

SHEET NO.

DATE:

2 of 7

5/28/2015

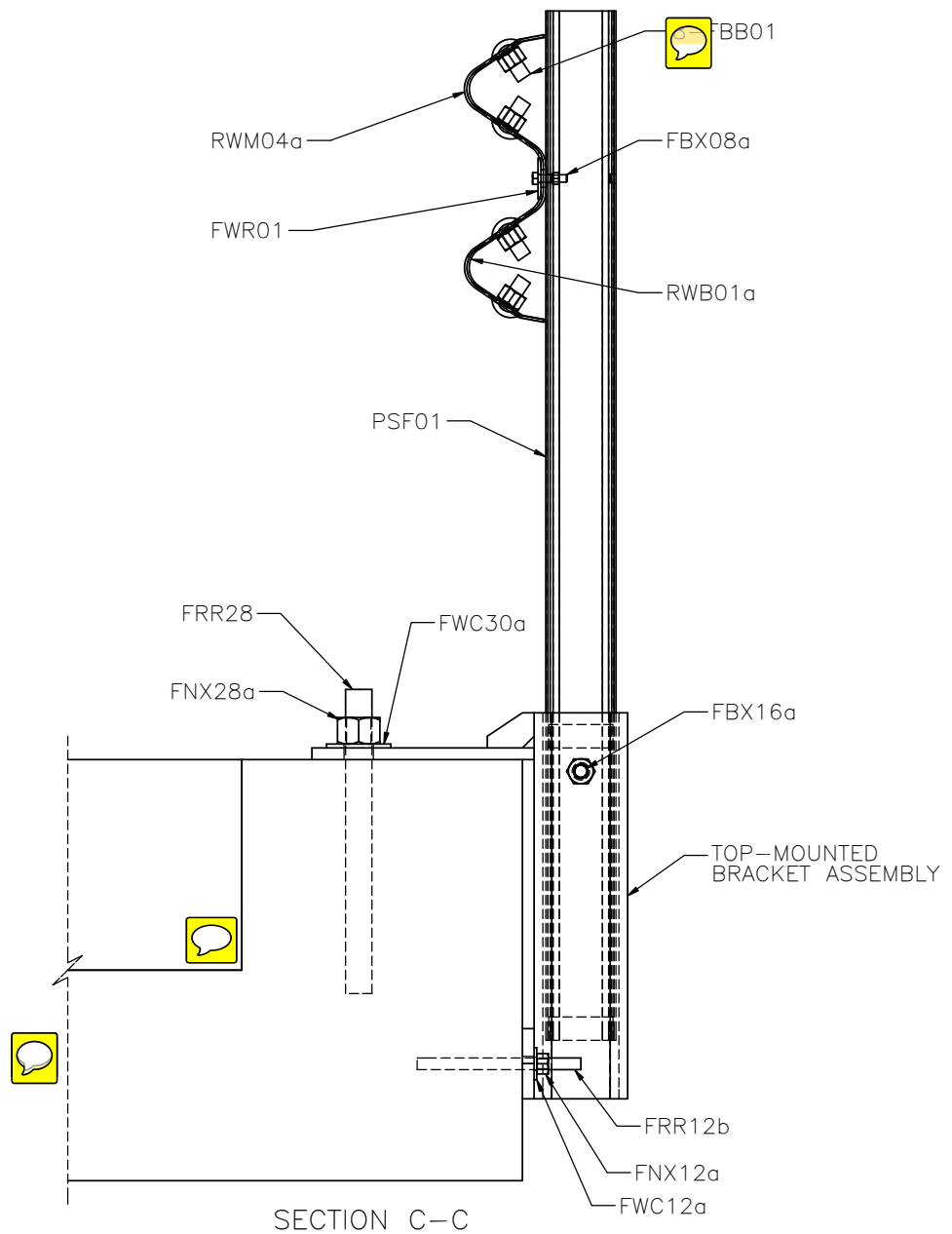

TOP-MOUNTED WEAK-POST GUARDRAIL ATTACHED TO CULVERT



SGR52

SHEET NO.

DATE:

3 of 7

5/28/2015

REFERENCES

Schneider, A.J., Rosenbaugh, S.K., Faller, R.K., Sicking, D.L., Lechtenberg, K.A., and Reid, J.D., *Safety Performance Evaluation of Weak-Post, W-Beam Guardrail Attached to Culvert*, Final Report to the Midwest States Pooled Fund Program, MwRSF Research Report No. TRP-03-277-14, Midwest Roadside Safety Facility, University of Nebraska-Lincoln, Lincoln, Nebraska, February 12, 2014.

Rosenbaugh, S.K., Faller, R.K., Lechtenberg, K.A., and Bielenberg, R.W., *Weak-Post, W-Beam Guardrail Attachment to Culvert Headwalls*, Paper No. 14-3930, Transportation Research Record No. 2437, Journal of the Transportation Research Board, TRB AFB20 Committee on Roadside Safety Design, Transportation Research Board, Washington D.C., January 2014, pages 41-51.

CONTACT INFORMATION

Midwest Roadside Safety Facility
University of Nebraska-Lincoln
130 Whittier Research Center
2200 Vine Street
Lincoln, NE 68583-0853
(402) 472-0965
Email: mwrsf@unl.edu
Website: <http://mwrsf.unl.edu/>

TOP-MOUNTED WEAK-POST GUARDRAIL ATTACHED TO CULVERT



SGR52

SHEET NO.

DATE:

4 of 7

5/28/2015

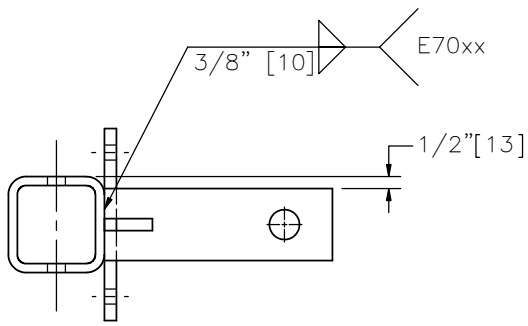

PLAN VIEW

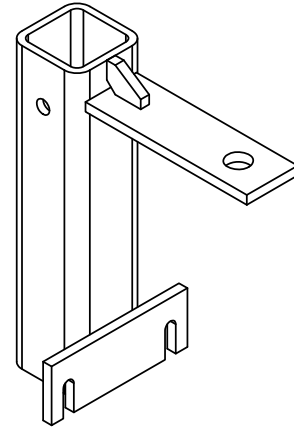

ISOMETRIC VIEW

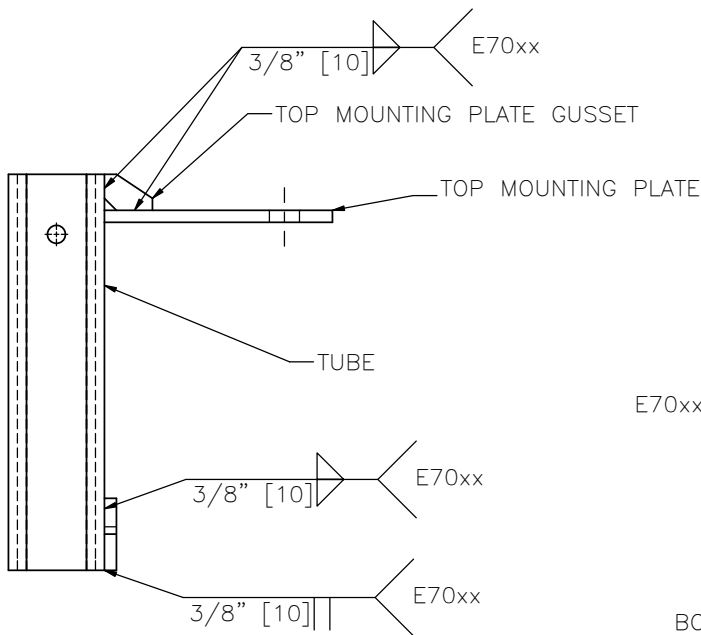

ELEVATION VIEW

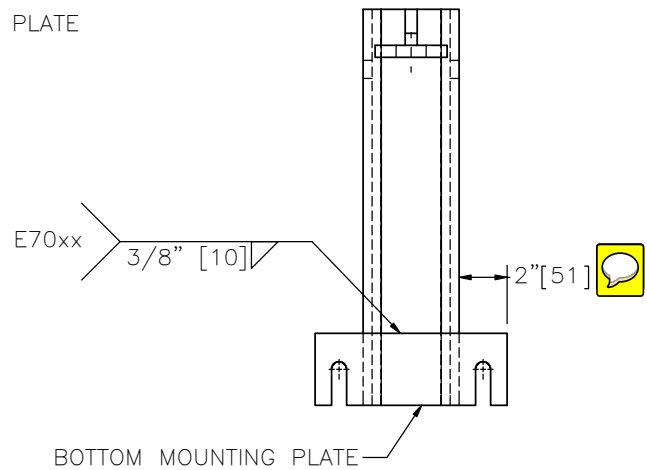

PROFILE VIEW

TOP-MOUNTED BRACKET ASSEMBLY

TOP-MOUNTED WEAK-POST GUARDRAIL ATTACHED TO CULVERT



SGR52

SHEET NO.

DATE:

5 of 7

5/28/2015

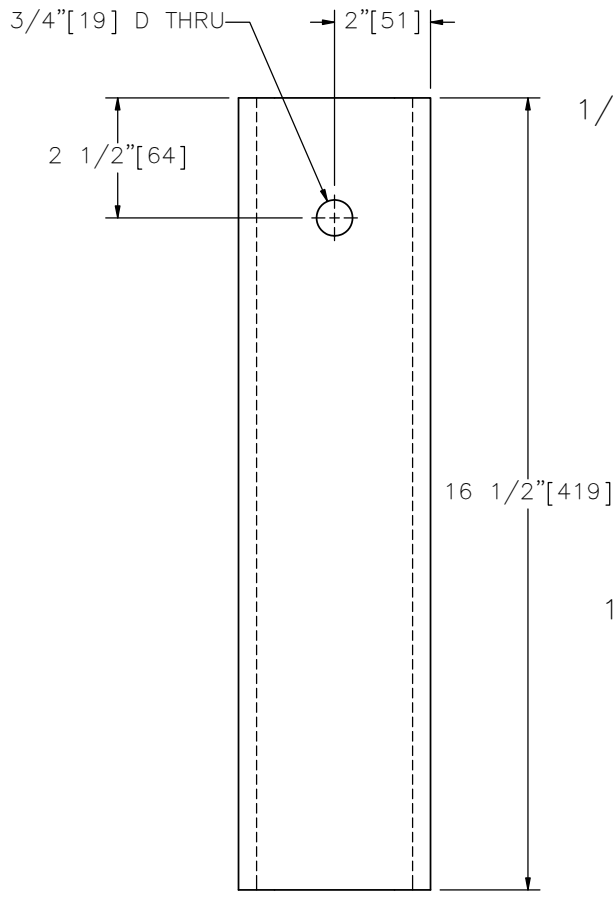

ELEVATION VIEW
4"x4"x3/8" [102x102x10] TUBE

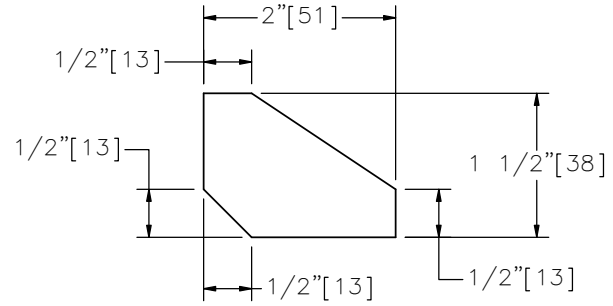

ELEVATION VIEW
1/2" [13] THICK TOP MOUNTING PLATE GUSSET

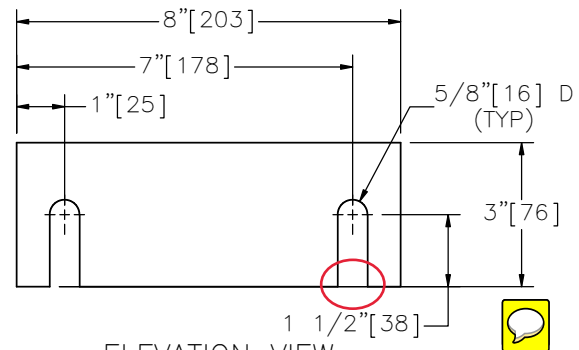

ELEVATION VIEW
1/2" [13] THICK BOTTOM MOUNTING PLATE

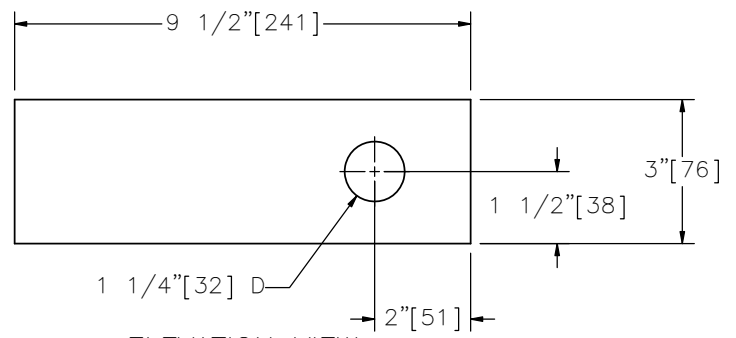

ELEVATION VIEW
1/2" [13] THICK TOP MOUNTING PLATE

TOP-MOUNTED WEAK-POST GUARDRAIL ATTACHED TO CULVERT



SGR52

SHEET NO.	DATE:
6 of 7	5/28/2015

x3/8"?

SPECIFICATIONS

4"x4" Square Tube

The square tube shall be ASTM A500 grade B galvanized steel.

Top Mounting Plate

The top mounting plate shall be ASTM A572 grade 50 galvanized steel.

Top Mounting Plate Gusset

The top mounting plate gusset shall be ASTM A572 grade 50 galvanized steel.

Bottom Mounting Plate

The bottom mounting plate shall be ASTM A572 grade 50 galvanized steel.

TOP-MOUNTED WEAK-POST GUARDRAIL ATTACHED TO CULVERT



SGR52

SHEET NO.

DATE:

7 of 7

5/28/2015