

PLAN

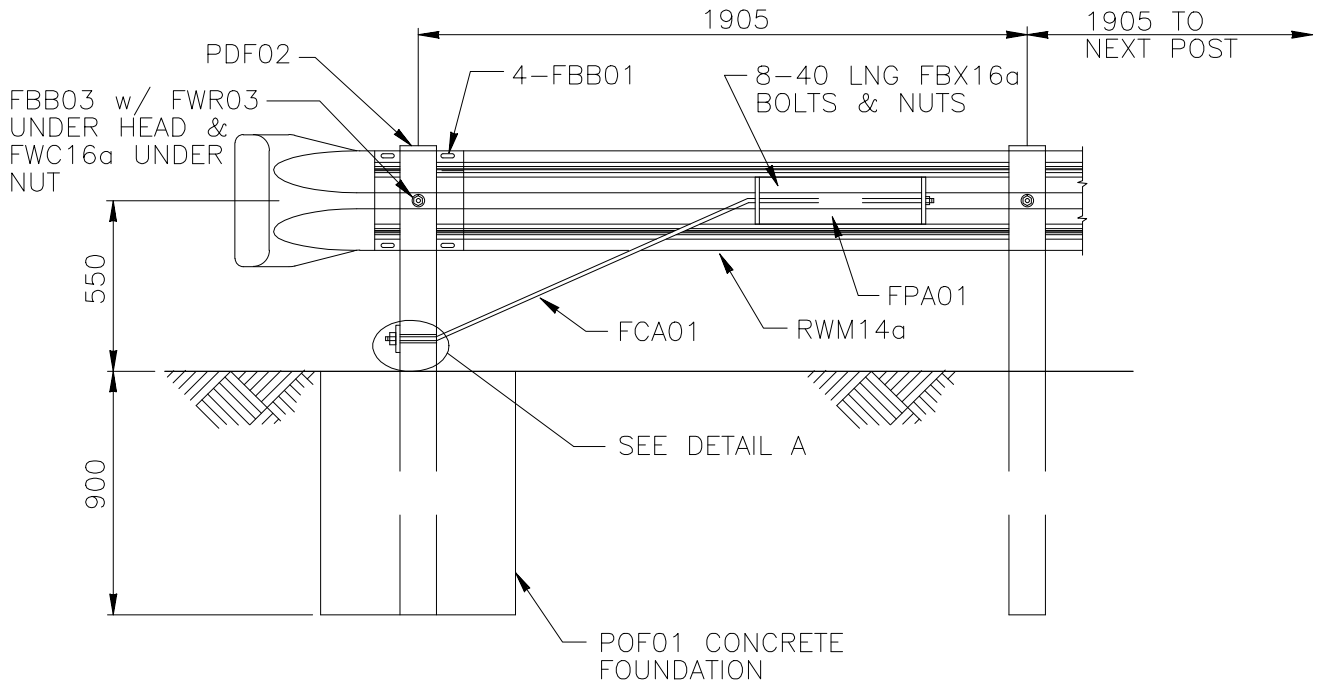

ELEVATION

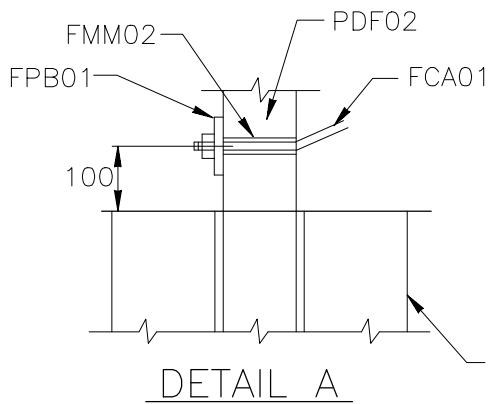

DETAIL A

NOTE:

POLYSTYRENE SHEETING, COMPOSITION PAPER OR SOME OTHER MATERIAL SHALL BE WRAPPED AROUND THE CONCRETE EMBEDDED PORTION OF THE POST TO AID IN REMOVING BROKEN OR DAMAGED POSTS.

1994

TRAILING END TERMINAL-CONCRETE FOOTING OPTION

SEW02b

SHEET NO.

REF. NO.

1 of 2