

**FULL-SCALE 18,000 LB. VEHICLE CRASH TEST
ON THE
KANSAS 32 INCH CORRAL RAIL**



by

James C. Holloway, E.I.T.
Research Associate Engineer

Brian G. Pfeifer, E.I.T.
Research Associate Engineer

Ronald K. Faller, E.I.T.
Research Associate Engineer

Edward R. Post, Ph.D., P.E.
Professor of Civil Engineering

Submitted to

Ron Seitz, P.E.
Road Design
Kansas Department of Transportation
Docking State Office Building
Topeka, Kansas 66612-1568

Project RES1 (0099) P450
TRANSPORTATION RESEARCH REPORT TRP-03-26-91

Midwest Roadside Safety Facility
Civil Engineering Department
W348 Nebraska Hall
University of Nebraska-Lincoln
Lincoln, Nebraska 68588-0531

July 1991

DISCLAIMER STATEMENT

The contents of this report reflect the views of the authors who are responsible for the facts and the accuracy of the data presented herein. The contents do not necessarily reflect the official views or policies of the Kansas Department of Transportation or the Federal Highway Administration. This report does not constitute a standard, specification, or regulation.

ACKNOWLEDGEMENTS

The authors wish to express their appreciation and thanks to the following people who made a contribution to the outcome of this research project.

Kansas Department of Transportation

Ron Seitz, P.E., Road Design Squad Leader

Federal Highway Administration

Bill Wendling, P.E., Safety Program Engineer

Nebraska Department of Roads

Dalyce Ronnau, Materials and Test Division Research Engineer

University of Nebraska-Lincoln

Tom Grady (E.E. Technician)

Tom Hoffman (Instrument Maker III)

Midwest Roadside Safety Facility

Syed Ataullah (Graduate Research Assistant)

Jim Luedke (C.E. Student)

Terry Atkins (C.E. Student)

Virgil Oligmueller (C.E. Student)

Craig Rockwell (C.E. Student)

Greg Prang (M.E. Student)

Private

Jim Dunlap (Dunlap Photography)

ABSTRACT

One full-scale crash test was conducted on the Kansas 32 in. Corral Rail. Test KSCR-1 was conducted with an 18,040 lb. test vehicle at 15 degrees and 51.5 mph. The point of impact was located midway between the fourth and fifth posts relative to the upstream end. The post spacing was 10 ft - 0 in. The installation was 100 ft long and was constructed with a simulated bridge deck.

The test was evaluated according to the safety criteria in the National Cooperative Highway Research Program (NCHRP) Report 230 and the American Association of State Highway and Transportation Officials "Guide Specifications for Bridge Railings", 1989. The safety performance of the Kansas 32 in. Corral Rail was determined to be satisfactory.

TABLE OF CONTENTS

| | Page |
|--|------|
| DISCLAIMER STATEMENT | i |
| ACKNOWLEDGEMENTS | ii |
| ABSTRACT | iii |
| TABLE OF CONTENTS | iv |
| LIST OF FIGURES | vi |
| LIST OF TABLES | viii |
| 1 INTRODUCTION | 1 |
| 1.1 Problem Statement | 1 |
| 1.2 Objective of Study | 1 |
| 2 TEST CONDITIONS | 2 |
| 2.1 Test Facility | 2 |
| 2.1.1 Test Site | 2 |
| 2.1.2 Vehicle Tow System | 2 |
| 2.1.3 Vehicle Guidance System | 2 |
| 2.2 Kansas 32 in. Corral Rail Design Details | 6 |
| 2.3 Test Vehicle | 12 |
| 2.4 Data Acquisition Systems | 19 |
| 2.4.1 Accelerometers | 19 |
| 2.4.2 High-Speed Photography | 19 |
| 3 PERFORMANCE EVALUATION CRITERIA | 25 |

| | Page |
|---|------|
| 4 TEST RESULTS | 28 |
| 4.1 Test No. KSCR-1 | 28 |
| 5 CONCLUSIONS | 41 |
| 6 RECOMMENDATIONS | 44 |
| 7 REFERENCES | 45 |
| 8 APPENDICES | 46 |
| A. Concrete Compressive Strengths | 47 |
| B. Relevant Correspondence | 49 |
| C. Accelerometer Data Analysis | 52 |

LIST OF FIGURES

| | Page |
|---|------|
| 1. Full-Scale Crash Test Facility | 3 |
| 2. Cable Tow and Guidance Systems | 4 |
| 3. Tow Vehicles and Fifth Wheel | 5 |
| 4. Details of the Kansas 32 in. Corral Rail | 7 |
| 5. Cross section of Deck assembly | 8 |
| 6. 32 in. Kansas Corral Rail | 9 |
| 7. 32 in. Kansas Corral Rail (continued) | 10 |
| 8. Bridge rail and Deck Construction | 11 |
| 9. Test Vehicle | 13 |
| 10. Test Vehicle Dimensions | 14 |
| 11. Locations of center of gravity | 15 |
| 13. Target Locations | 18 |
| 14. Accelerometers and the onboard vehicle metraplex unit | 20 |
| 15. Flow Chart of Data Acquisition System | 21 |
| 16. Data recorder and 386/AT computer | 22 |
| 17. Layout of High-Speed Cameras | 24 |
| 18. Test KSCR-1 Summary and Sequential Photographs | 29 |
| 19. Full-Scale Vehicle Crash Test, KSCR-1 | 30 |
| 20. Full Scale Vehicle Crash Test, KSCR-1 (cont.) | 31 |
| 21. Parallel Time-Sequential Photographs | 32 |
| 22. Rail Damage Between Posts No. 4 and No. 5 | 34 |

| | Page |
|---|------|
| 23. Rail Damage at point of impact | 35 |
| 24. Rail and Post damage at Post No. 5 | 36 |
| 25. Post No. 5 damage at splice and deck cracking | 37 |
| 26. Damage from vehicle riding along the rail | 38 |

LIST OF TABLES

| | Page |
|--|------|
| 1. Crash Test Conditions and Evaluation Criteria for the Permanent Precast CMB | 26 |
| 2. AASHTO Evaluation Criteria | 27 |
| 3. Safety Performance Results | 42 |
| 4. Summary of Test Results | 43 |

1 INTRODUCTION

1.1 Problem Statement

The Kansas Department of Transportation (KDOT) was interested in using the Kansas Corral Rail on bridges in its Interstate Systems. For this to be possible, the system had to pass the PL-2 performance level tests described in AASHTO (1). The 27-in. Kansas Corral Rail had previously been tested with an 1,800 lb. vehicle and a 4,500 lb. vehicle (2) in accordance with NCHRP 230 (3). The AASHTO "Guide Specification for Bridge Railings" (1) requires that a bridge rail at the PL-2 performance level have a minimum vertical height of 32 in. Therefore, the height of the Kansas Corral Rail was increased to 32 in. to comply with this requirement. An 18,000 lb. vehicle test was then conducted to complete the test matrix for the PL-2 performance level.

1.2 Objective of Study

The objective of the research study was to evaluate the safety performance of the Kansas 32 in. Corral Rail by conducting a full-scale vehicle crash test in accordance with the "Guide Specifications for Bridge Railings," AASHTO (1), and "Recommended Procedures for the Safety Performance Evaluation of Highway Appurtenances," NCHRP 230 (3). Thus, a full-scale vehicle crash test was performed to evaluate the structural adequacy, occupant risk, and redirection characteristics of the bridge rail.

2 TEST CONDITIONS

2.1 Test Facility

2.1.1 Test Site

The test site facility was located at Lincoln Air-Park on the NW end of the west apron of the Lincoln Municipal Airport. The test facility, shown in Figure 1, is approximately 5 mi. NW of the University of Nebraska-Lincoln.

An 8 ft high chain-link security fence surrounds the test site facility to ensure that no vandalism occurs to the test articles or test vehicles which could possibly disrupt the results of the tests.

2.1.2 Vehicle Tow System

A reverse cable tow, with a 1:2 mechanical advantage, was used to propel the test vehicle. The distance traveled and the speed of the tow vehicle are one-half that of the test vehicle. A sketch of the cable tow system is shown in Figure 2. The test vehicle was released from the tow cable approximately 20 ft before impact with the Kansas 32 in. Corral Rail. The tow vehicle and the attached fifth-wheel are shown in Figure 3. The fifth-wheel, built by the Nucleus Corporation, was used in conjunction with a digital speedometer to increase the accuracy of the test vehicle impact speed.

2.1.3 Vehicle Guidance System

A vehicle guidance system, developed by Hinch (4), was used to steer the test vehicle. The guidance system is shown in Figure 2. The guide flag, attached to the front left wheel and the guide cable, was sheared off 20 ft before impact with the Kansas 32 in. Corral Rail. The 3/8 in. diameter guide cable was tensioned to 3,000 lbs., and supported laterally and vertically every

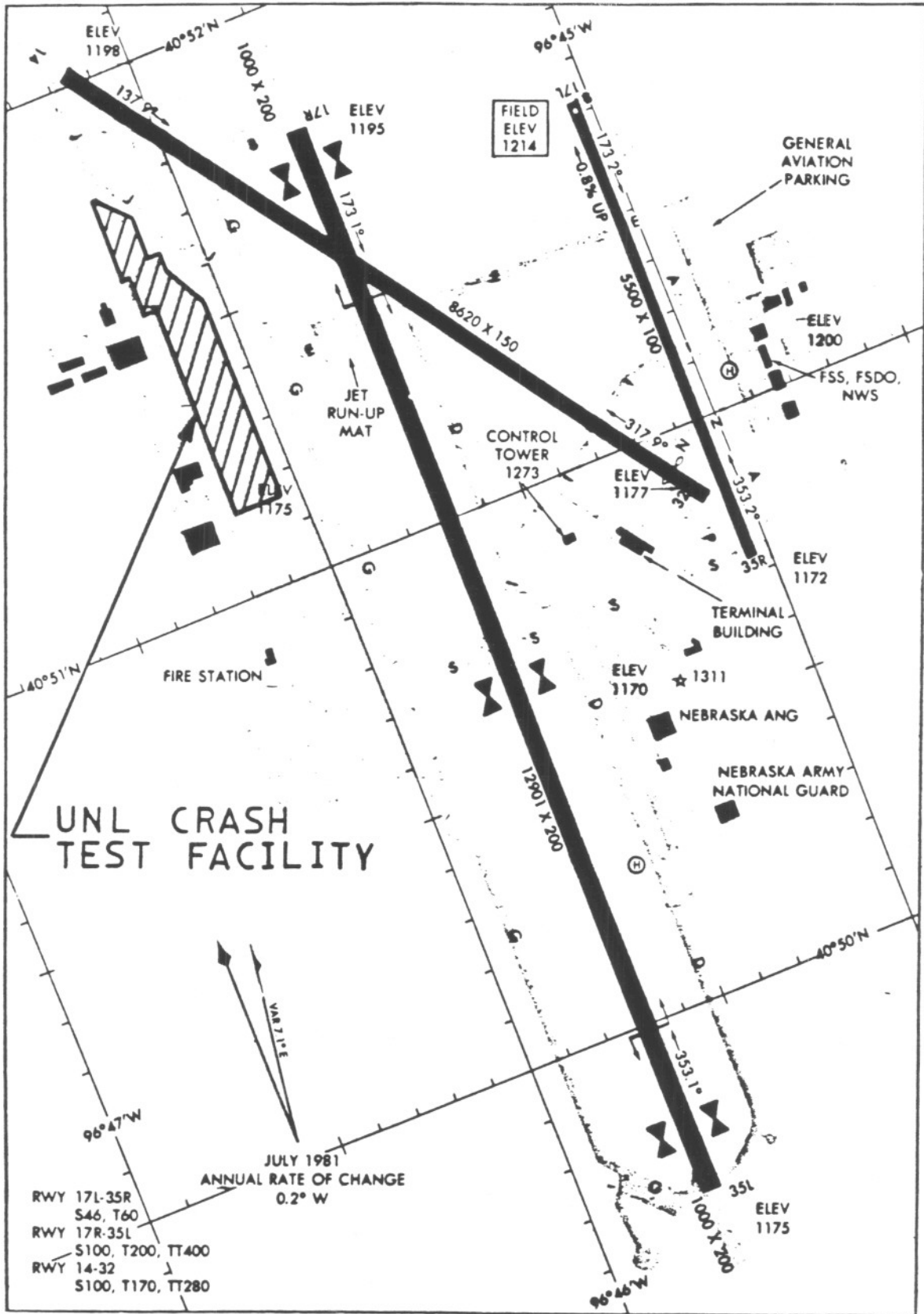

Figure 1. Full-Scale Crash Test Facility

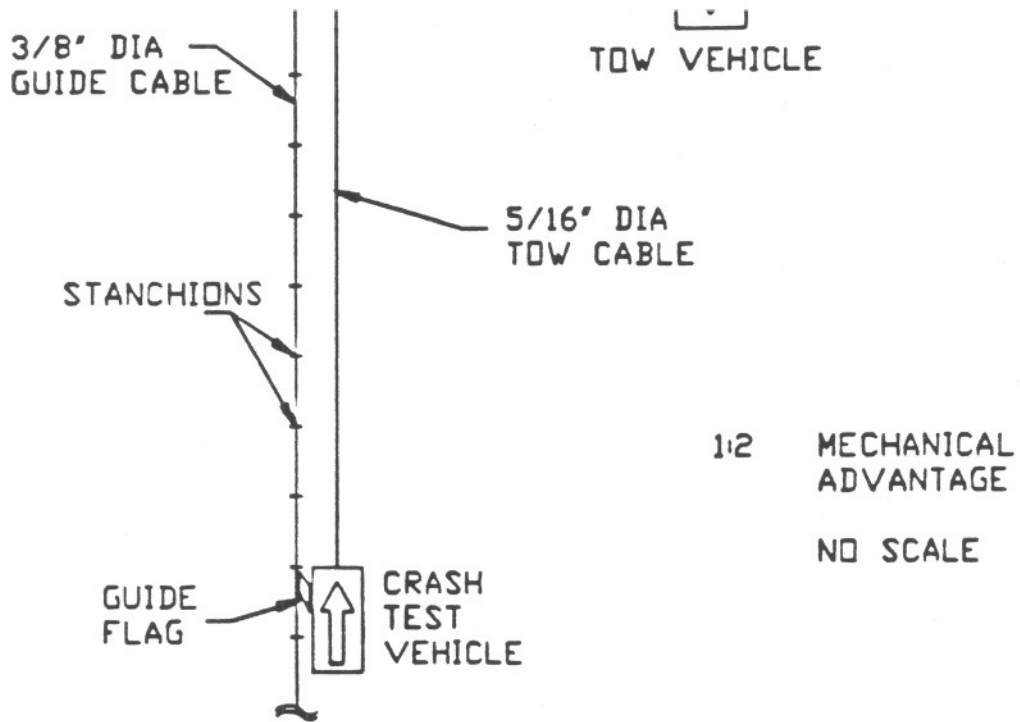

Figure 2. Cable Tow and Guidance Systems

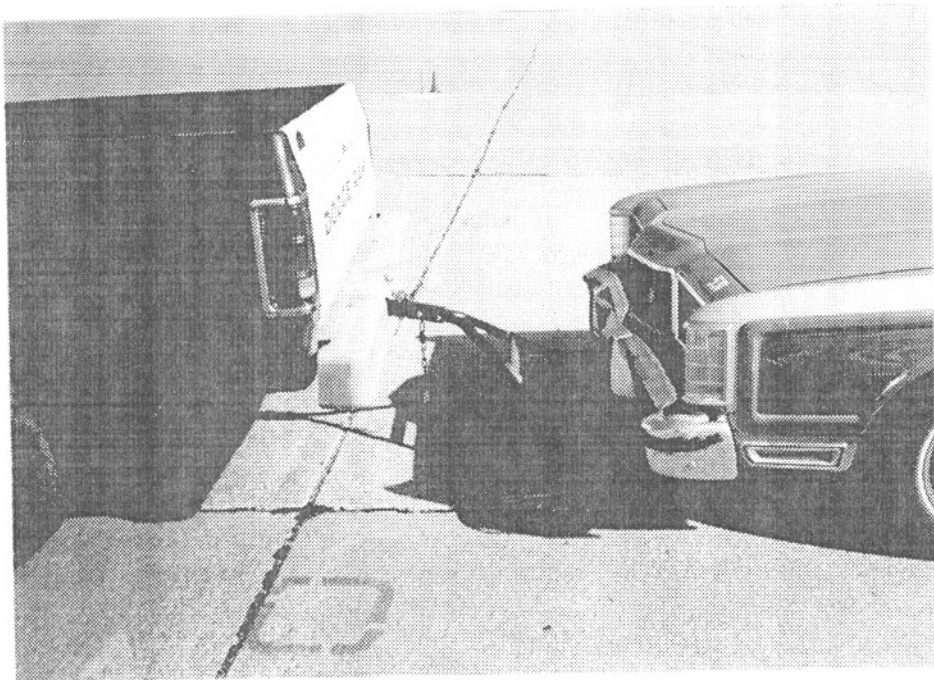

Figure 3. Tow Vehicles and Fifth Wheel

100 ft by hinged stanchions. The hinged stanchions stood upright while holding up the guide cable. As the vehicle was towed down the line, the guide-flag struck each stanchion and knocked it to the ground. The vehicle guidance system was approximately 2,000 ft in length.

2.2 Kansas 32 in. Corral Rail Design Details

A detailed drawing of the Kansas 32 in. Corral Rail is shown in Figure 4. Photographs of the actual installation are shown in Figures 5 and 6. The total length of the installation was 100 ft. The installation consisted of three major structural components: simulated concrete bridge deck, concrete bridge rail, and concrete posts.

The installation was constructed with a simulated bridge deck in order to test the rail to deck connection, in addition to the rail itself. A cross-section of the simulated bridge deck is shown in Figure 7. The 8 in. thick deck had a total width of 4 ft - 10.5 in. which produced a 2 ft - 1.5 in. overhang. The deck was reinforced with two No.5 transverse bars spaced at 6 in. centers. The top bar had 2.5 in. of cover and the bottom bar had 1 in. of cover. Two No. 5 longitudinal bars were placed between the transverse bars and spaced at 12 in. centers. The transverse bars were attached to the existing concrete apron. The connection detail is also shown in Figure 7. Grade 60 epoxy coated reinforcement was used in the deck. The reinforcement layout is shown in Figure 8.

The second major component of the installation was the concrete bridge rail, consisting of ten 10 ft sections, each with six longitudinal No.5 bars. This reinforcement was also epoxy coated Grade 60 rebar. The layout is shown in Figure 8. The rail was 12 in. wide and had a bottom height of 13 in. and a top height of 32 in. A 0.5 in. open joint was located between each 10 ft section of rail at the center of each post. There was no end treatment of the rail.

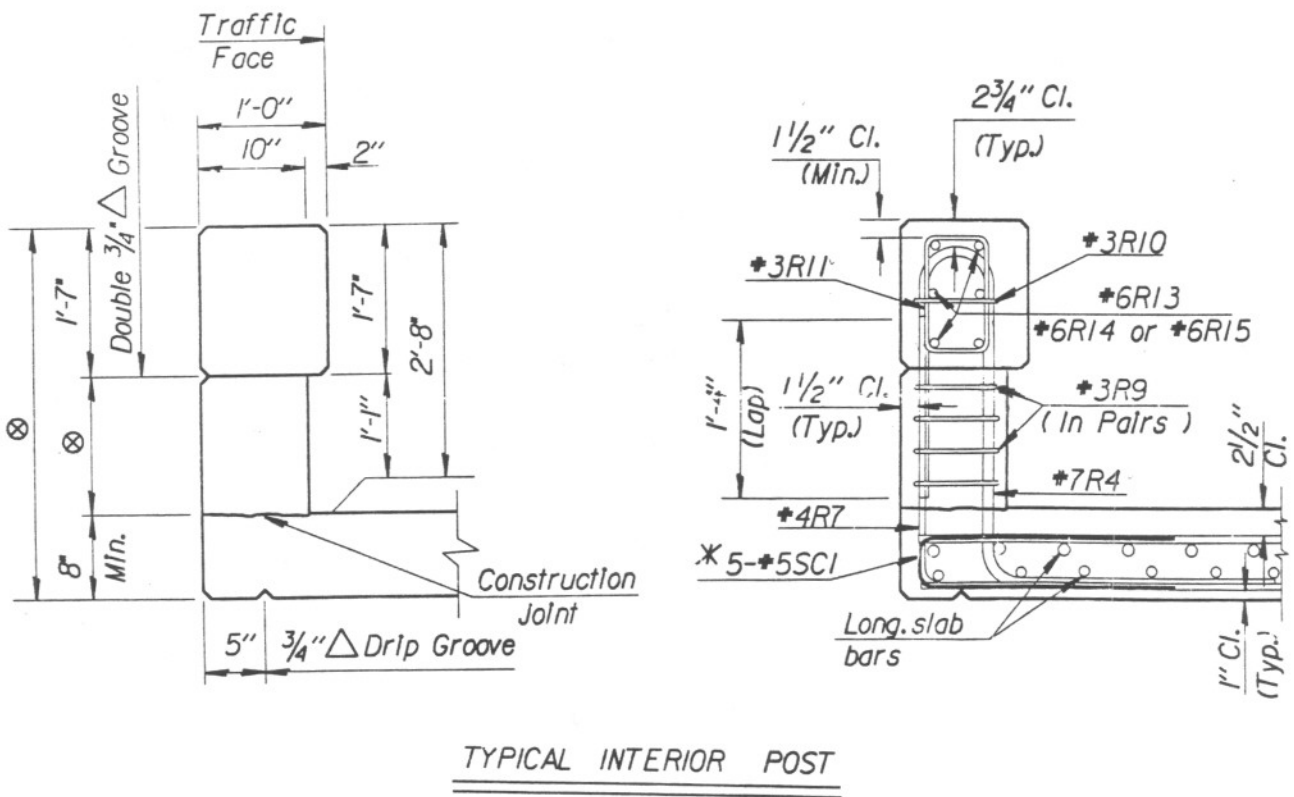
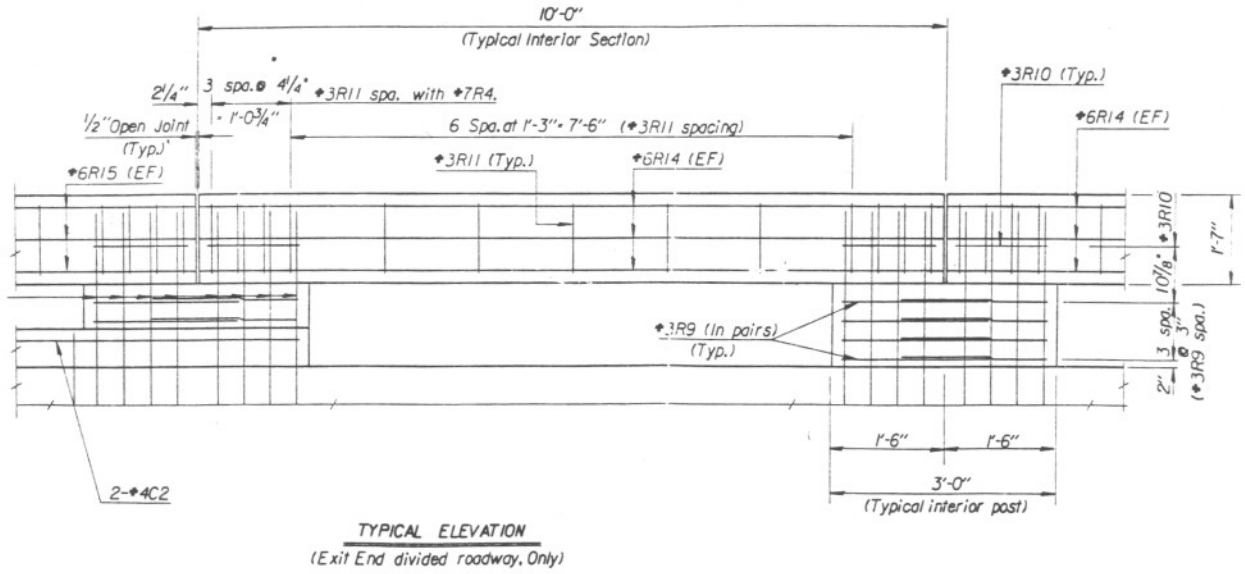

Figure 4. Details of the Kansas 32 in. Corral Rail

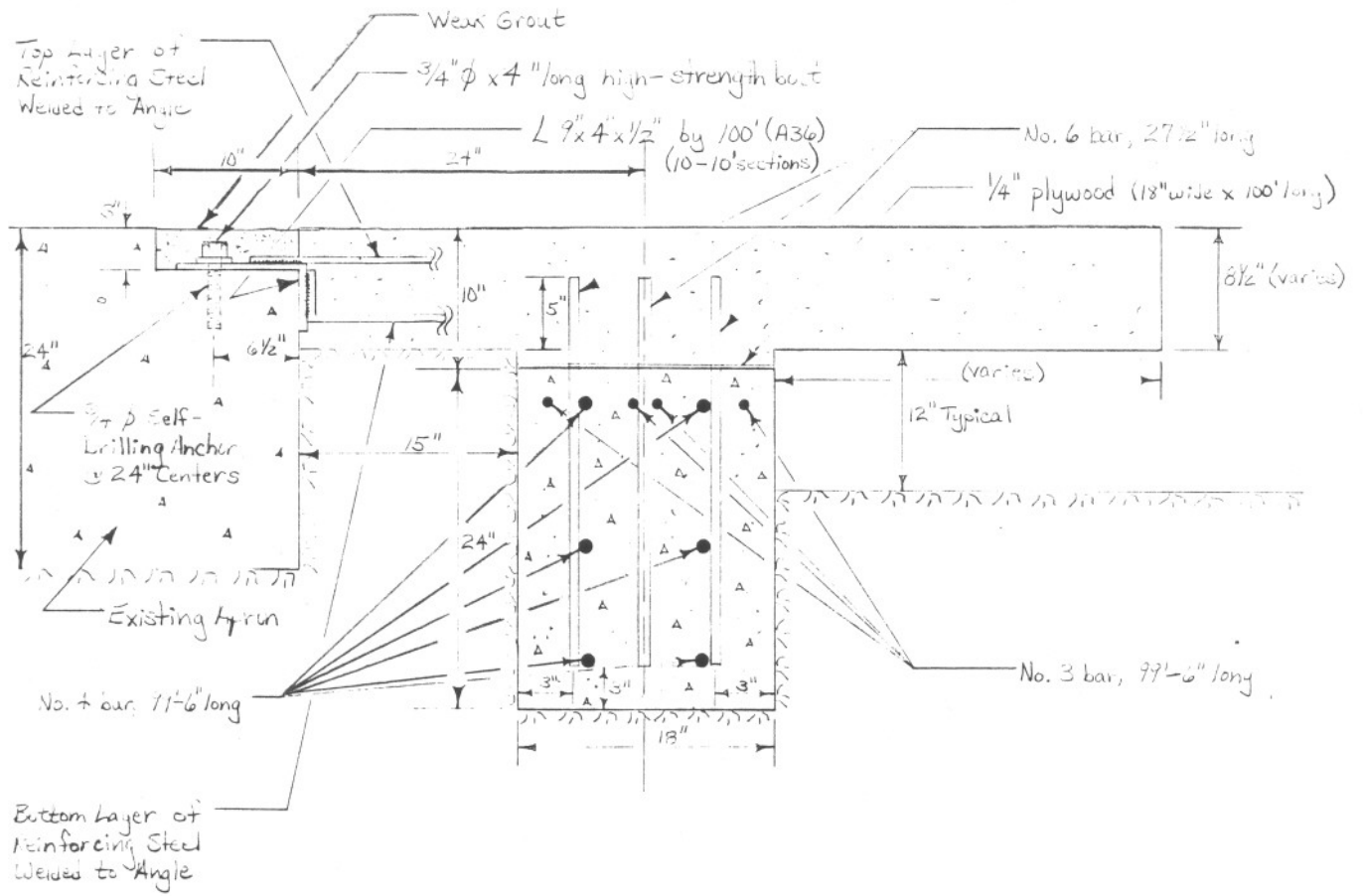

Figure 5. Cross section of Deck assembly

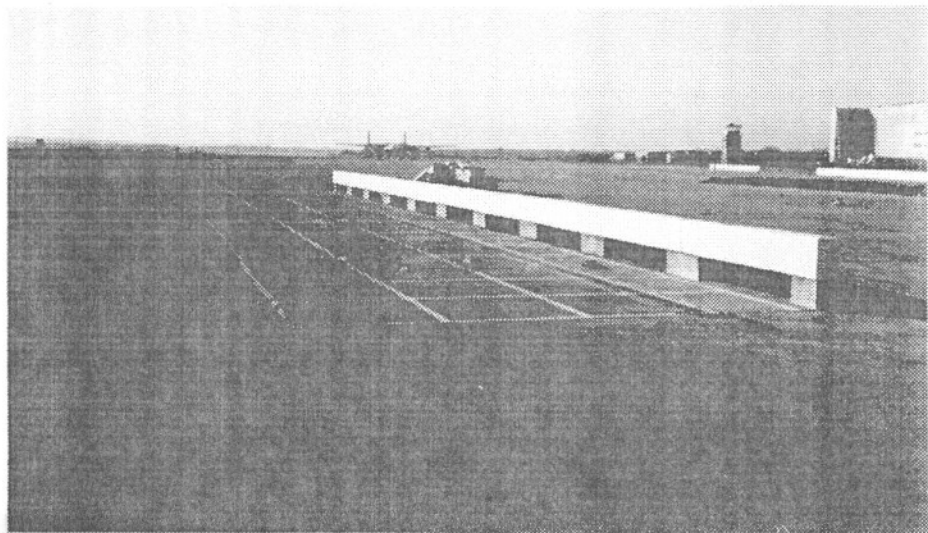
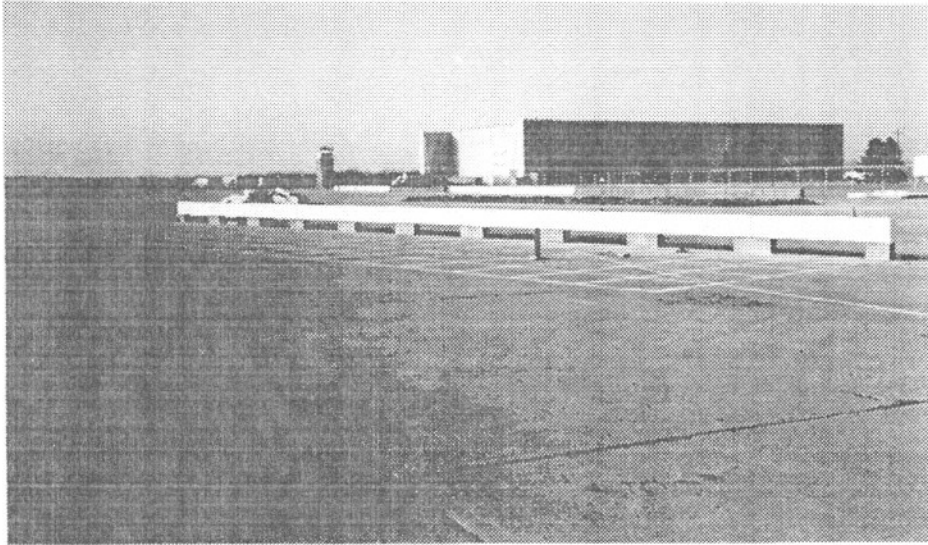
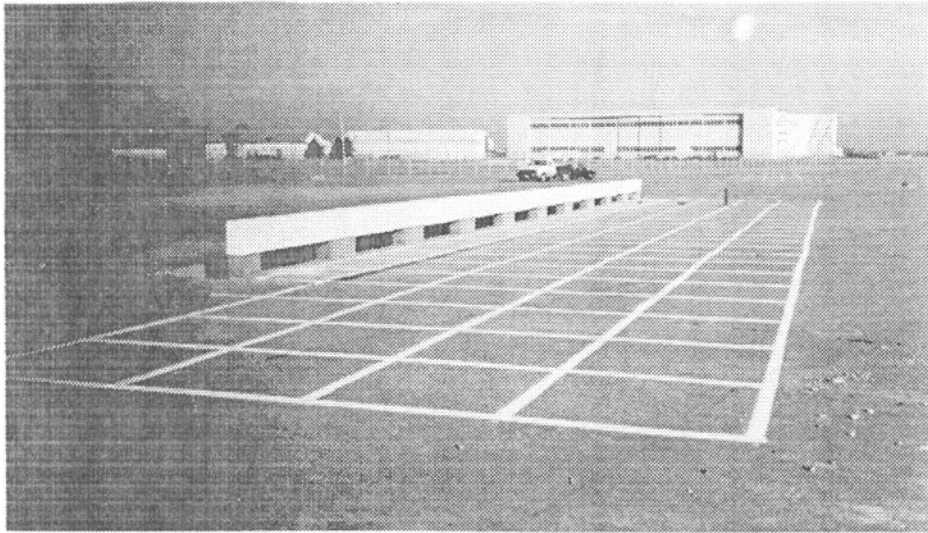

Figure 6. 32 in. Kansas Corral Rail

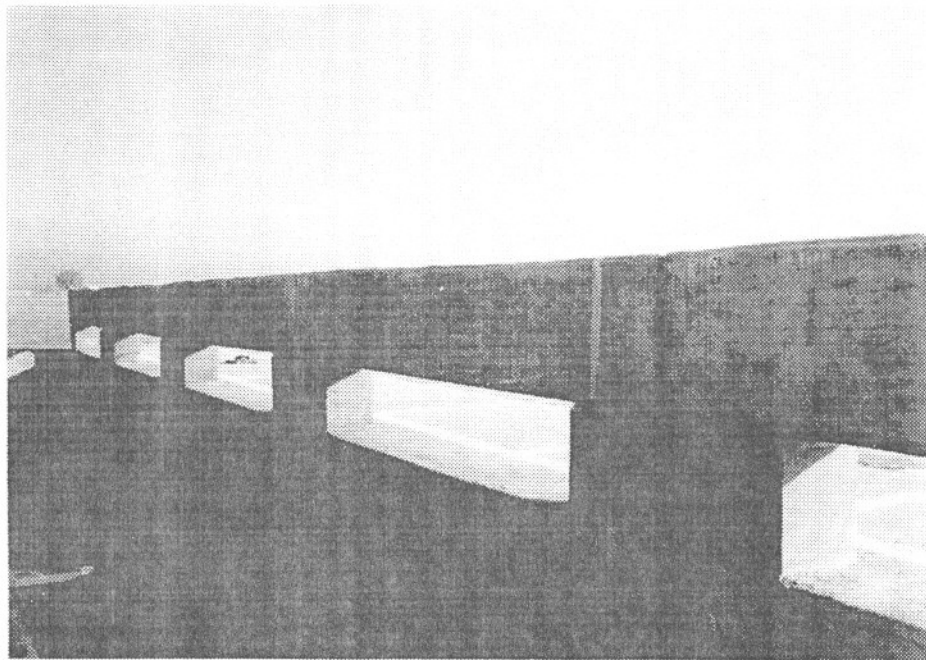
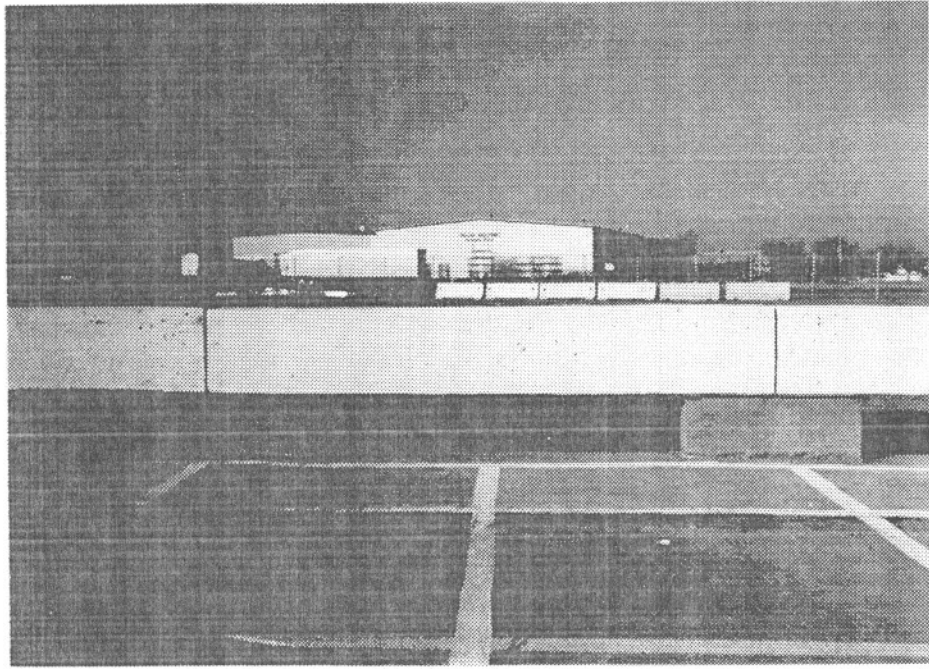

Figure 7. 32 in. Kansas Corral Rail (continued)

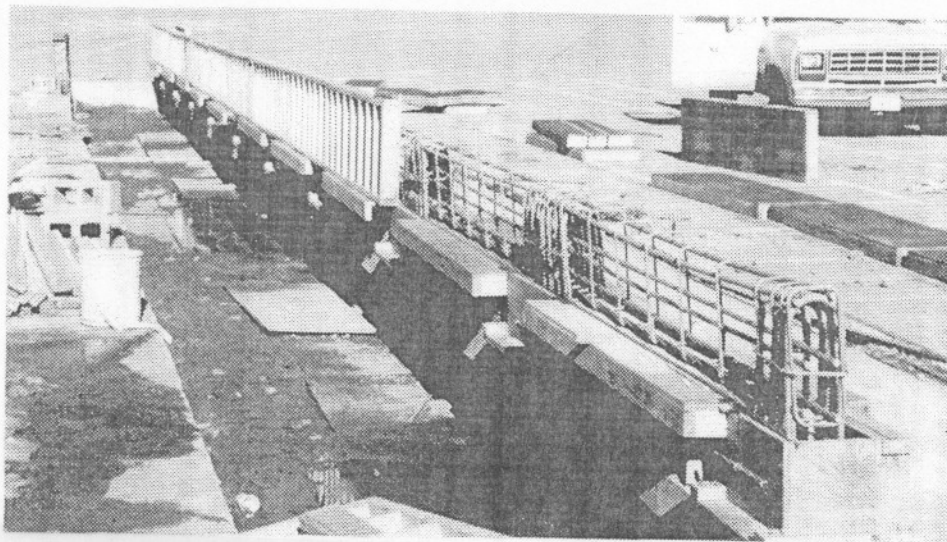
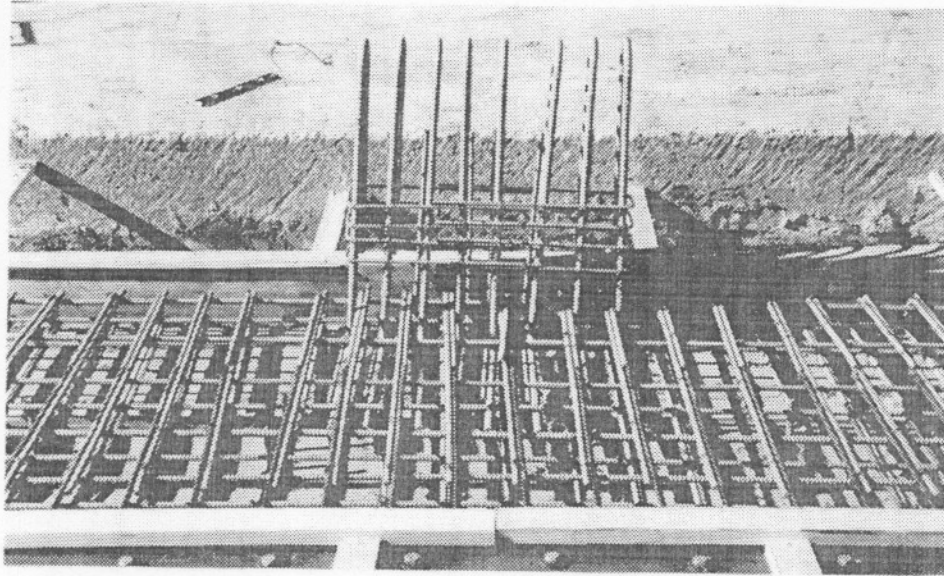
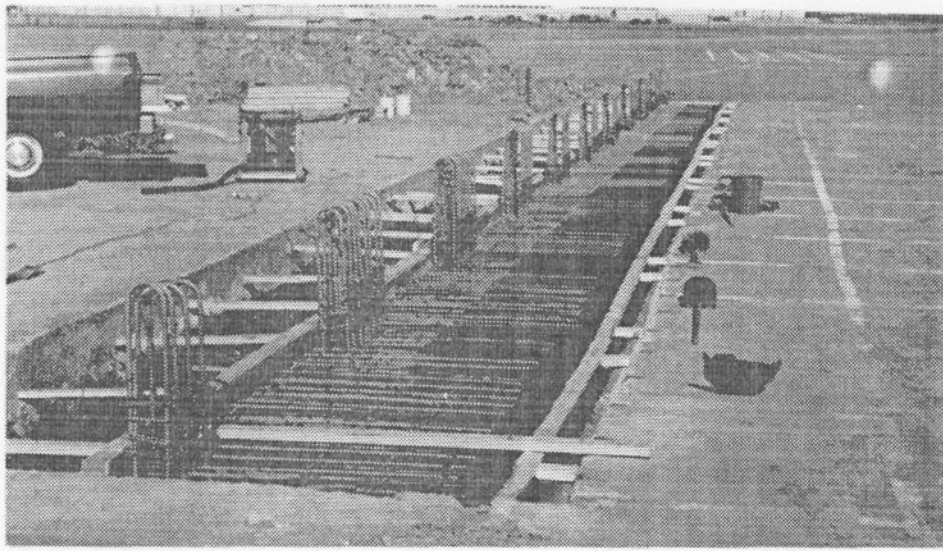

Figure 8. Bridge rail and Deck Construction

The third component of the installation was the concrete post. There were nine full-section posts and two half-section posts. The full-section posts were 10 in. wide by 3 ft long with a 13 in. height. The posts were spaced at 10 ft centers. The full section posts were reinforced with eight vertical No. 7 bars along the traffic face and eight vertical No. 4 bars along the backside of the post.

The concrete used for all of the above components was a Nebraska 47-B Special Mix with a minimum compressive strength of 4,000 psi. This was a comparable mix to that of the KDOT specifications. Five percent air entrainment was used in the mix. The concrete compressive strengths of the (1) concrete deck and (2) concrete rail and posts at the time of the test were 5,360 psi and 4,560 psi respectively. The results of the concrete compressive tests are shown in Appendix A.

The rail and posts were poured on December 12, 1990. Due to the cold temperatures at the time of casting, the installation was covered and heated to insure proper curing of the concrete.

2.3 Test Vehicle

The test vehicle was a 1984 GMC 7000 Series single unit truck having a test inertial weight of 18,040 lbs. The test vehicle is shown in Figure 9, and the vehicle dimensions are shown in Figure 10.

The ballast used for the test vehicle consisted of a reinforced concrete block which was bolted to the walls and the floor of the box. The location of the ballast is shown in Figure 11. The reinforcement used was ASTM A325 all-thread rod. The vertical reinforcement was 5/8 in. rod and the transverse reinforcement was 1/2 in. rod. This reinforcement design was capable of

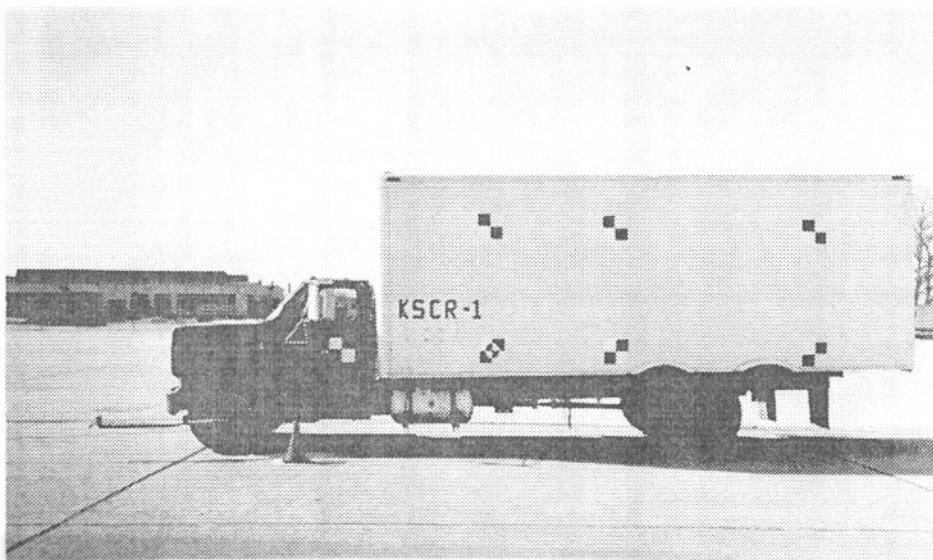
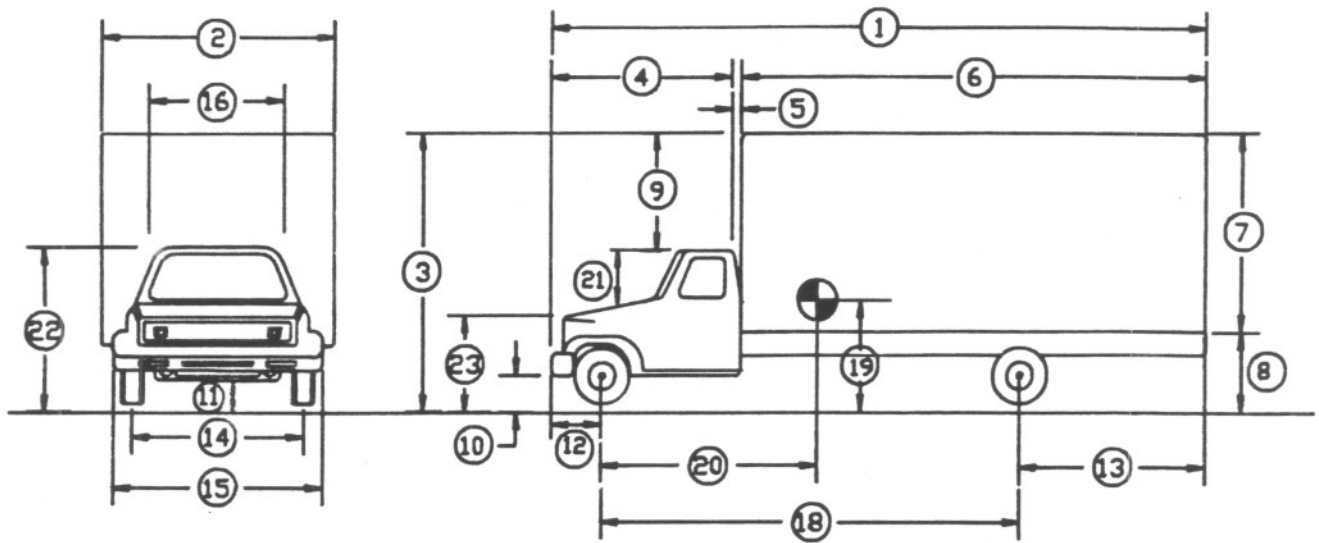

Figure 9. Test Vehicle



Model 1984 GMC 7000 Series

Total Weight 18,040 lb.

Front Weight 5,240 lb.

Rear Axle Weight 7,960 lb.

Ballast 4,840 lb.

- | | |
|--|--|
| ① Overall Length <u>361.0</u> | ⑬ Rear Overhang <u>108.0</u> |
| ② Overall Width <u>90.0</u> | ⑭ Front Track Width <u>76.0</u> |
| ③ Overall Front Height <u>137.0</u> | ⑮ Front Bumper Width <u>89.0</u> |
| ④ Cab Length <u>94.0</u> | ⑯ Roof Width <u>57.5</u> |
| ⑤ Gap Length <u>4.0</u> | ⑰ Typical Tire Size and Diameter <u>39.5</u> |
| ⑥ Trailer/Box Length <u>262.0</u> | ⑱ Wheel Base <u>224.0</u> |
| ⑦ Rear Body Height <u>101.0</u> | ⑲ C.G. Height <u>49.0</u> |
| ⑧ Rear Ground Clearance <u>36.0</u> | ⑳ C.G. Longitudinal Distance <u>123.1</u> |
| ⑨ Roof Height Differential <u>47.5</u> | ㉑ Roof-Hood Distance <u>22.0</u> |
| ⑩ Front Ground Clearance <u>20.0</u> | ㉒ Roof Height <u>86.0</u> |
| ⑪ Minimum Ground Clearance <u>11.5</u> | ㉓ Hood Height <u>62.0</u> |
| ⑫ Front Overhang <u>30.5</u> | |

Note: All measurements are in inches.

Figure 10. Test Vehicle Dimensions

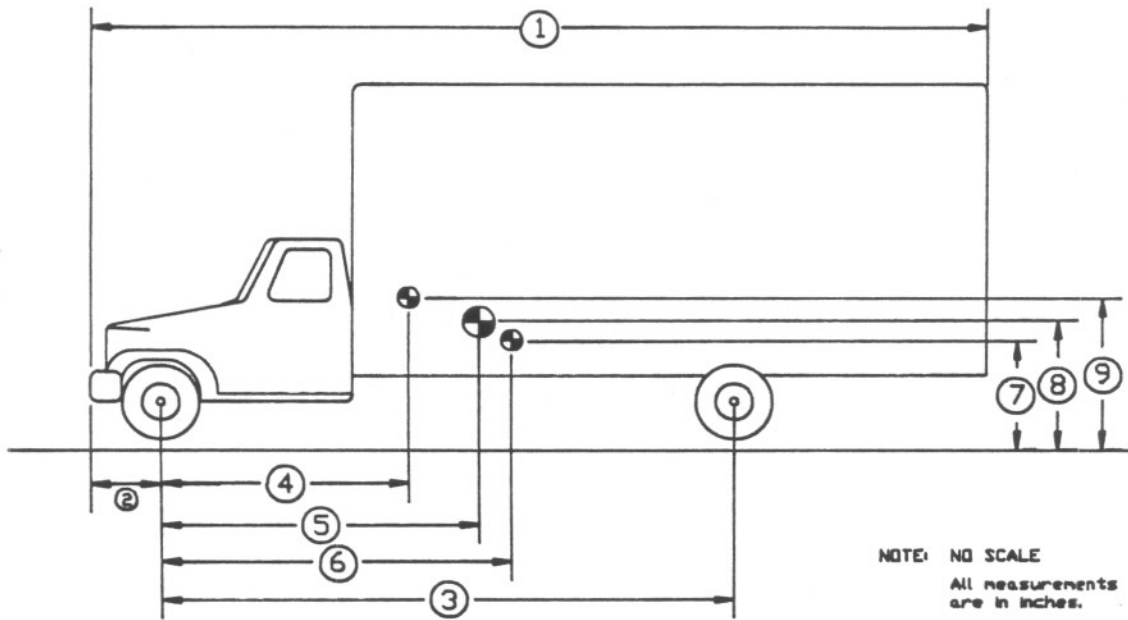

- ① Overall Length 361.0
- ② Front Overhang 30.5
- ③ Wheel Base 224.0
- ④ Ballast C.G. Longitudinal Distance 89.0
- ⑤ Total Weight C.G. Longitudinal Distance 123.1

- ⑥ Unballasted C.G. Longitudinal Distance 135.0
- ⑦ Unballasted C.G. Height 46.5
- ⑧ Total Weight C.G. Height 49.0
- ⑨ Ballast C.G. Height 56.0

Figure 11. Locations of center of gravity

sustaining loads equivalent to 20 times the mass of the concrete block. The reinforcement arrangement and the concrete block are shown in Figure 12.

The suspension method was used to calculate the center of gravity. This method is based on the principle that the center of gravity of any freely suspended body is in the vertical plane through the point of suspension. The vehicle was successively suspended in three positions, and the respective planes containing the center of gravity were established. The intersection of these planes located the center of gravity. This location is shown in Figure 11.

Twelve 12-in. square, black and white checkered targets were placed on the vehicle. These targets were used in the high speed film analysis. Two targets were located on the center-of-mass, one on the top and one on the side of the test vehicle. The remaining targets were located such that they could be viewed from both the perpendicular and overhead cameras. The target locations are shown in Figure 13.

The front wheels of the test vehicle were aligned for camber, caster, and toe-in values of zero so that the vehicle would track properly along the guide cable.

Two 5B flash-bulbs were mounted on the roof of the test vehicle to record the time of impact with the Kansas 32 in. Corral Rail on the high-speed film. The flash bulbs were fired by a pressure tape switch mounted on the front face of the bumper.

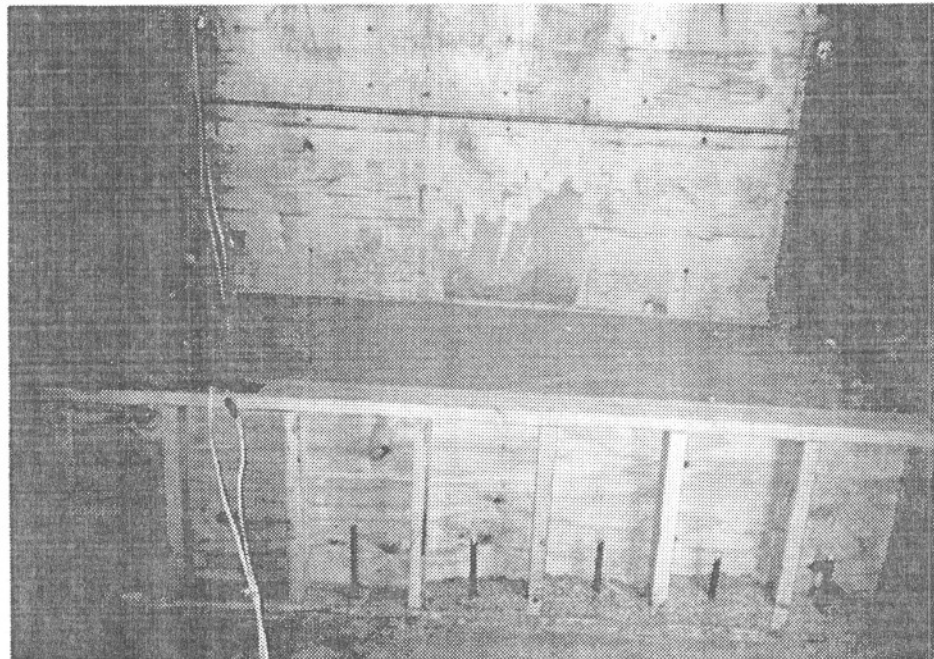
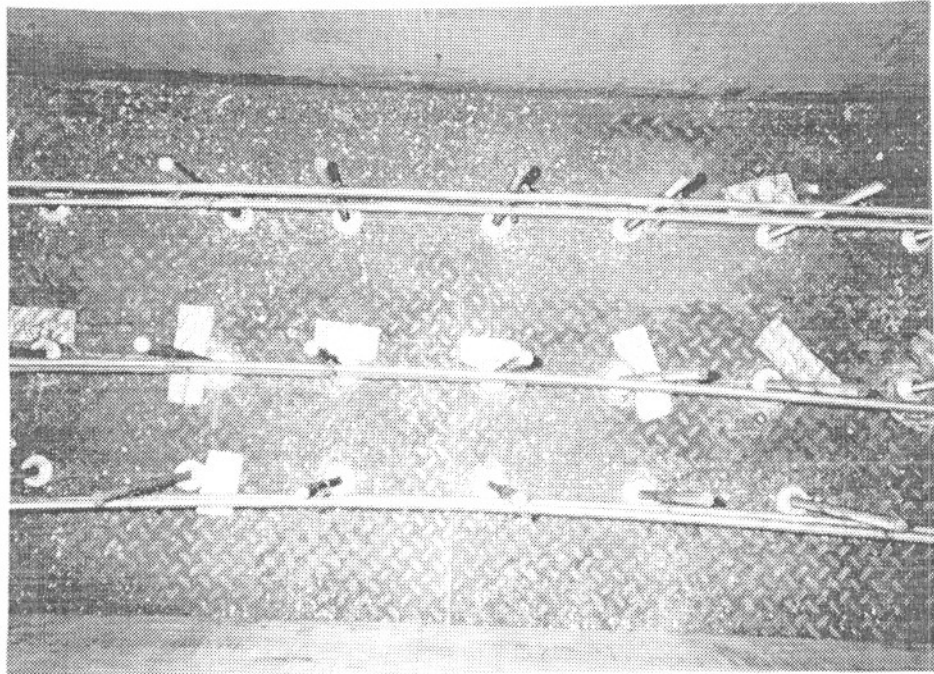

Figure 12. Concrete block used for ballast

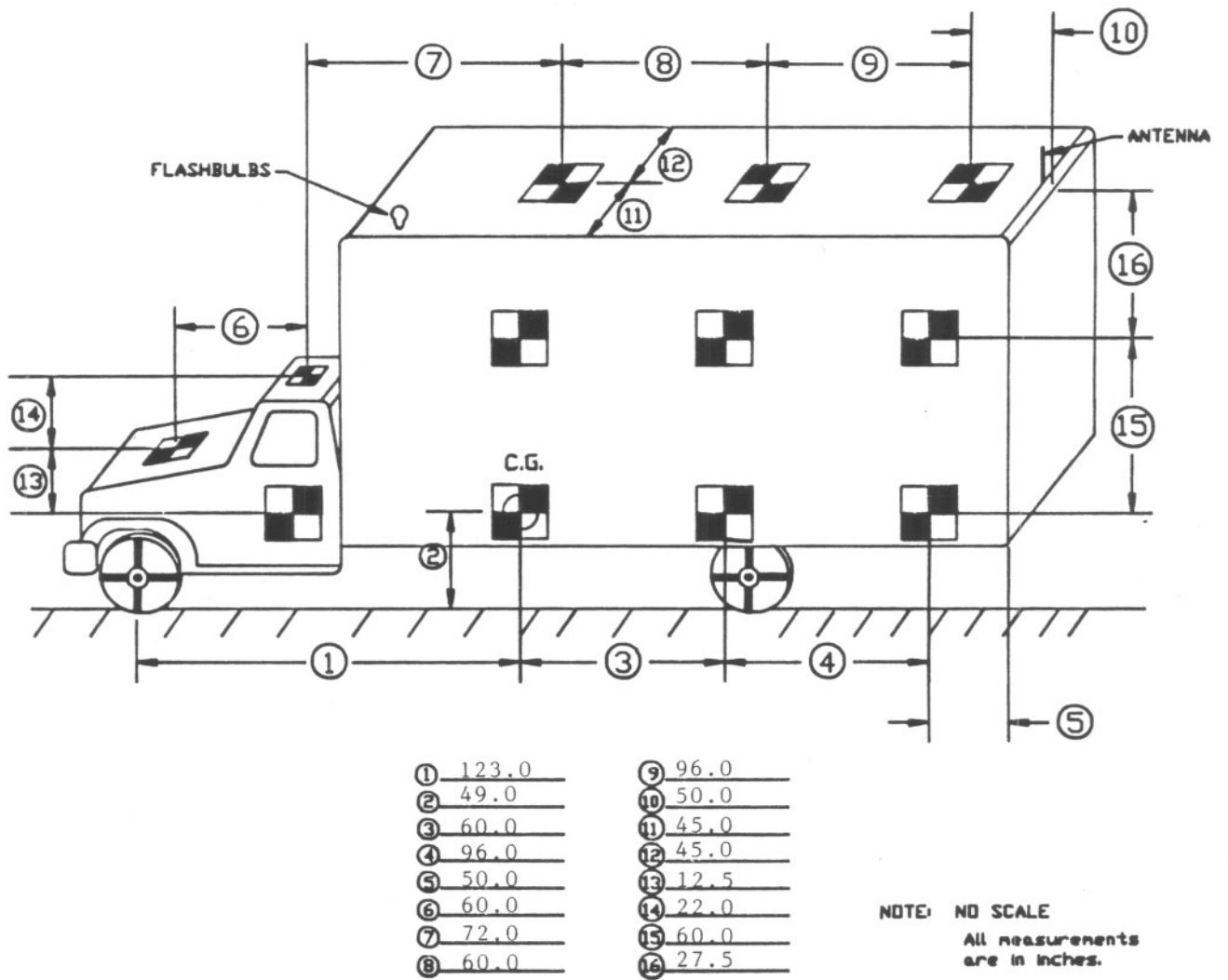

Figure 13. Target Locations

2.4 Data Acquisition Systems

2.4.1 Accelerometers

Four Endevco triaxial piezoresistive accelerometers (Model 7264) with a range of +/- 200 g's were used to measure the accelerations in the longitudinal and lateral directions of the test vehicle. Two accelerometers were mounted in each of the two directions so that there would be two accelerometer traces for validation of results. The accelerometers were rigidly attached to a metal block mounted at the center-of-mass. The accelerometers are shown in Figure 14. The signals from the accelerometers were received and conditioned by an onboard vehicle Metraplex Unit, which is also shown in Figure 14. The multiplexed signal was then radio transmitted to the Honeywell 101 Analog Tape Recorder in the central control van. A flow chart of the accelerometer data acquisition system is shown in Figure 15, and photographs of the system located in the centrally controlled step van are shown in Figure 16. State-of-the-art computer software, "Computerscope and DSP", was used to analyze and plot the accelerometer data on a Cyclone 386/AT, which uses a high-speed data acquisition board.

2.4.2 High-Speed Photography

Three high-speed 16 mm cameras were used to film the crash test. The cameras operated at approximately 500 frames/sec. The overhead camera was a Red Lake Locam with a wide angle 12.5 mm lens. It was placed approximately 64 ft above the concrete apron. The parallel camera was a Photec IV with an 80 mm lens. It was placed 300 ft downstream from the point of impact and offset 3 ft from a line parallel to the barrier rail. The perpendicular camera was a Photec IV with a 55 mm lens. It was placed 165 ft from the vehicle point of impact. A schematic of all three camera locations is shown in Figure 17.

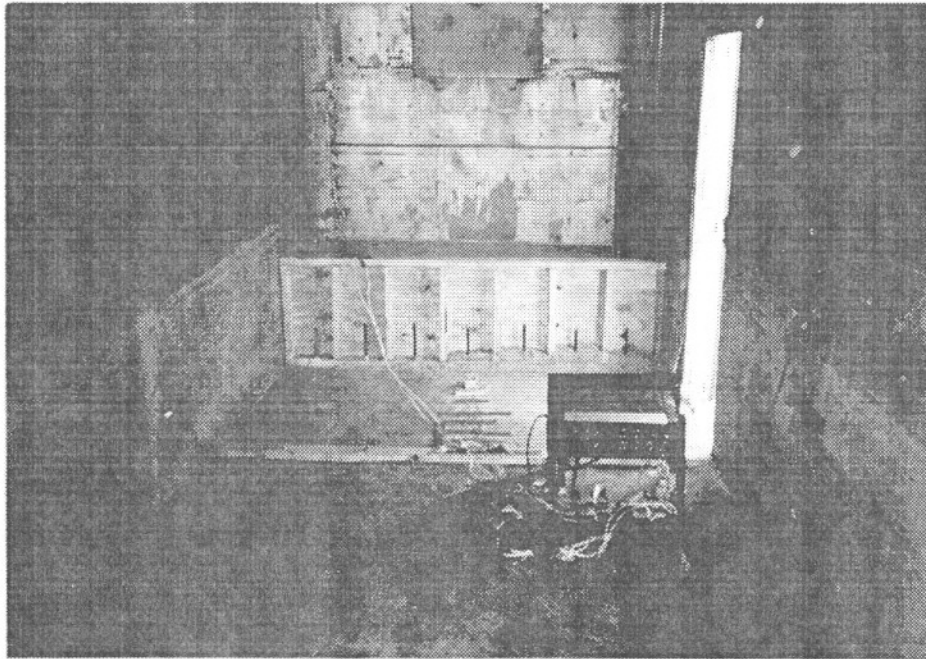
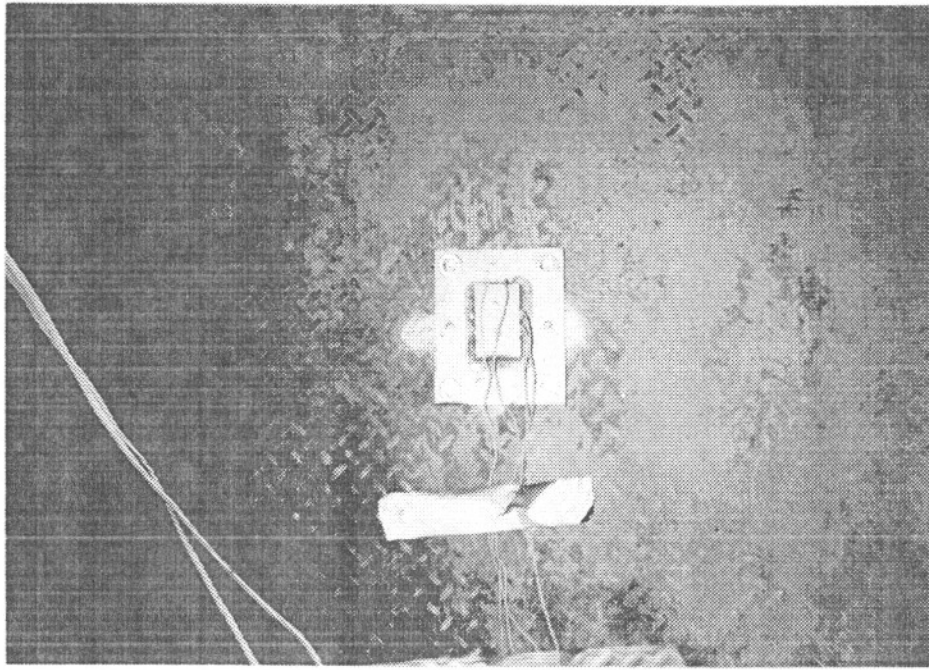

Figure 14. Accelerometers and the onboard vehicle metraplex unit

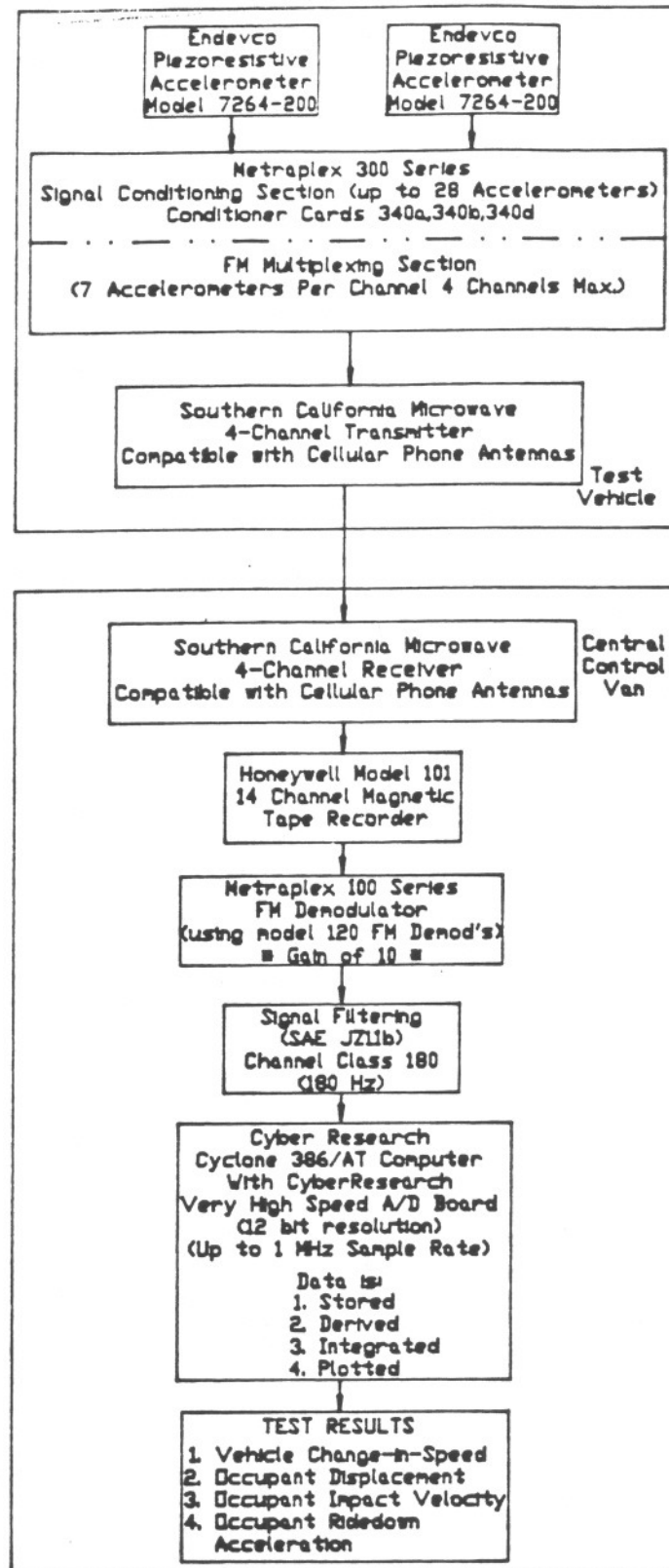

Figure 15. Flow Chart of Data Acquisition System

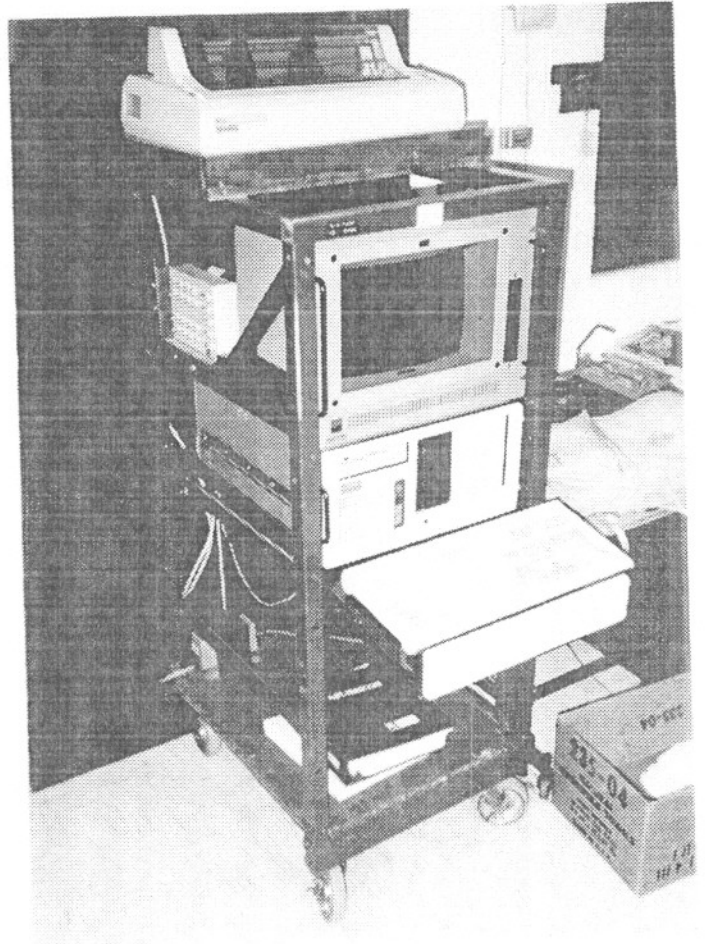
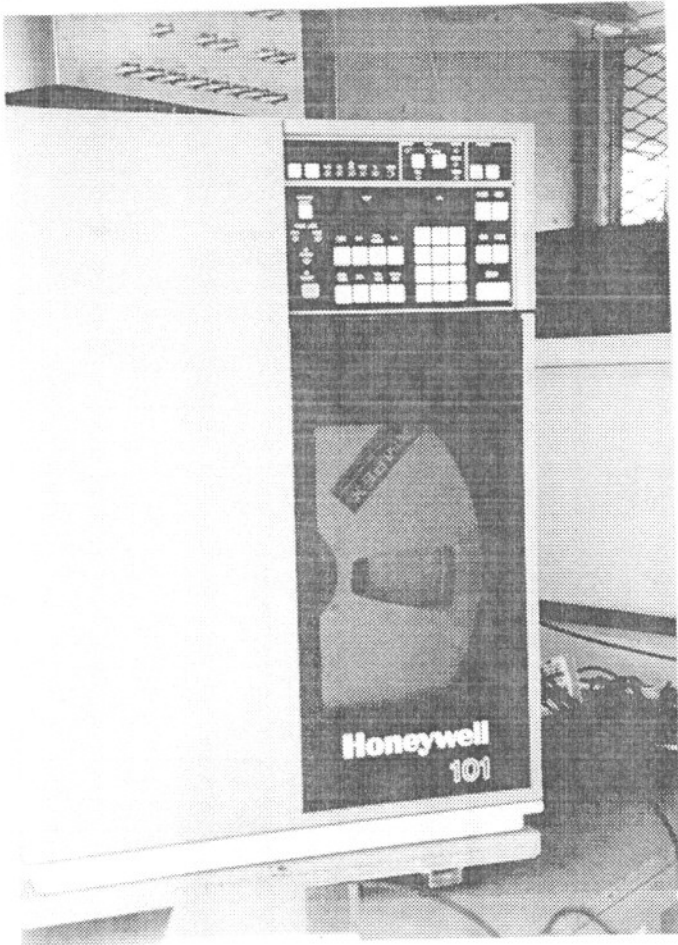

Figure 16. Data recorder and 386/AT computer

A 20 ft wide by 100 ft long grid layout was painted on the concrete slab surface parallel and perpendicular to the barrier. The white-colored grid was incremented with 5 ft divisions in both directions to give a visible reference system which could be used in the analysis of the overhead high-speed film.

The film was analyzed using the Vanguard Motion Analyzer. The camera divergence correction factors were also taken into consideration in the analysis of the high-speed film.

2.4.3. Speed Trap Switches

Eight tape pressure switches spaced at 5 ft intervals were used to determine the speed of the vehicle before and after impact. Each tape switch fired a strobe light as the left front tire of the test vehicle passed over it. The average speed of the test vehicle between the tape switches was determined by knowing the distance between pressure switches, the calibrated camera speed, and the number of frames from the high-speed film between flashes. In addition, the average speed was determined from electronic timing mark data, recorded on the oscilloscope software used with the 386/AT computer, as the test vehicle passed over each tape switch.

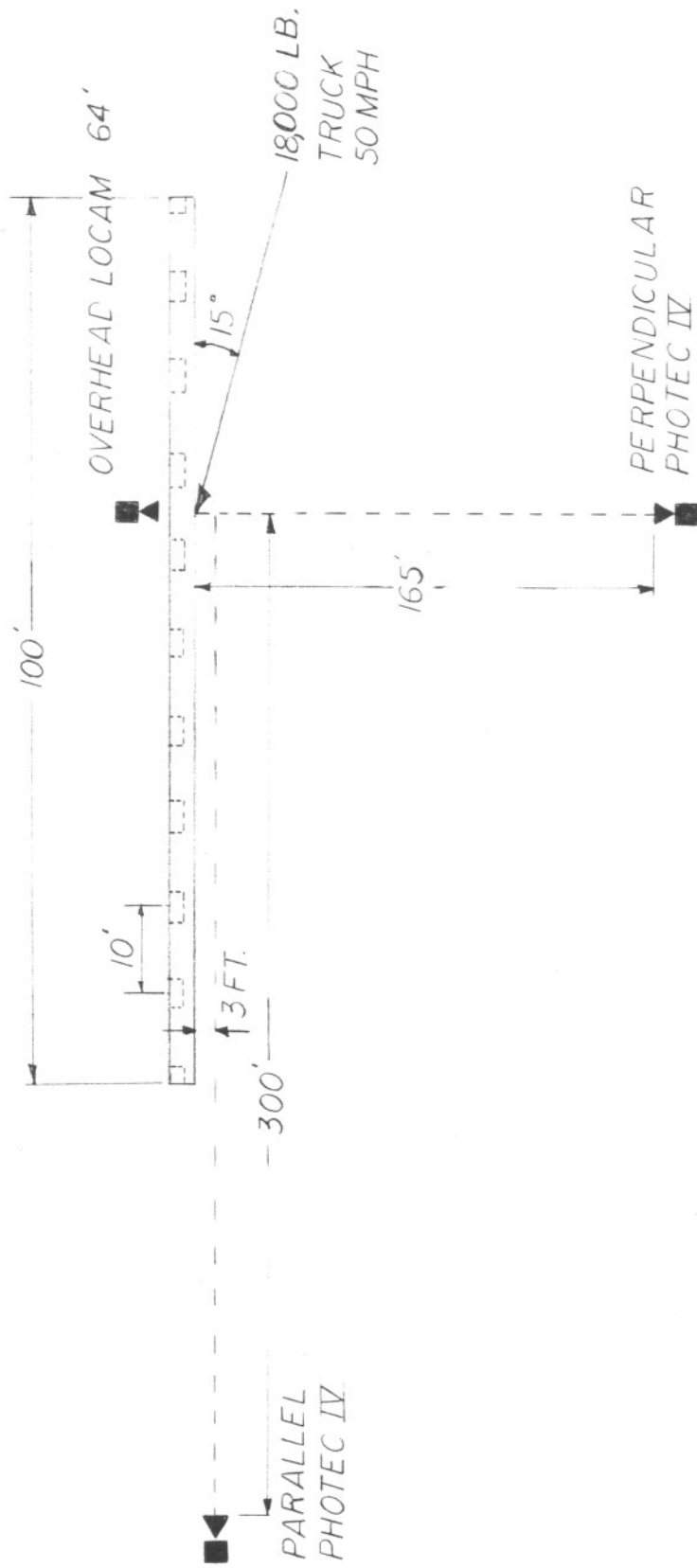

Figure 17. Layout of High-Speed Cameras

3 PERFORMANCE EVALUATION CRITERIA

The safety performance objective of a highway appurtenance is to minimize the consequences of a vehicle leaving the roadway to create an off-road incident. The safety goal is met when the appurtenance (Kansas 32 in. Corral Rail) smoothly redirects the vehicle away from a hazard zone without subjecting the vehicle occupants to major injury producing forces.

Safety performance of a highway appurtenance cannot be measured directly, but it can be evaluated according to three major factors: (1) structural adequacy, (2) occupant risk, and (3) vehicle trajectory after collision. These three factors are defined and explained in NCHRP 230(3). Similar criteria are presented in AASHTO (1).

Currently, there is not a specific test designation for the 18,000 lb. crash test in the NCHRP 230 Report (3). Therefore, there is not a specific set of evaluation criteria to meet from the NCHRP 230 Report (3). Thus, the evaluation criteria used to evaluate the crash test was taken from AASHTO (1). The test conditions for the matrix are shown in Table 1. Also, the specific evaluation criteria used to determine the adequacy of the barrier are listed in Table 2.

After each test, the vehicle damage was assessed by the traffic accident scale (TAD) (5) and the vehicle damage index (VDI) (6).

Table 1. Crash Test Conditions and Evaluation Criteria for the Kansas 32 in. Corral Rail

| Test Agency | Test Designation | Appurtenance | Test Vehicle | Speed (mph) | Angle (deg) | Required Criteria ¹ | Desirable Criteria ¹ |
|---------------|------------------|--------------|-----------------|-------------|-------------|--------------------------------|---------------------------------|
| AASHTO (1989) | PL-2 | Bridge | 18,000 lb Truck | 50 | 15 | 3. a,b,c | 3. d,e,f,h |

¹ Criteria described in Table 2.

Table 2. AASHTO Evaluation Criteria

| A. The test article shall contain the vehicle; neither the vehicle nor its cargo shall penetrate or go over the installation. Controlled lateral deflection of the test article is acceptable. | | | | | | | | | |
|--|-------------------------|-------------------|-------------|------|-------------|------|--------|----------|--|
| B. Detached elements, fragments or other debris from the test article shall not penetrate or show potential for penetrating the passenger compartment or present undue hazard to other traffic. | | | | | | | | | |
| C. Integrity of the passenger compartment must be maintained with no intrusion and essentially no deformation. | | | | | | | | | |
| D. The vehicle shall remain upright during and after collision. | | | | | | | | | |
| E. The test article shall smoothly redirect the vehicle. A redirection is deemed smooth if the rear of the vehicle does not yaw more than 5 degrees away from the railing from time of impact until the vehicle separates from the railing. | | | | | | | | | |
| F. The smoothness of the vehicle-railing interaction is further assessed by the effective coefficient of friction, μ , where $\mu = (\cos\theta - V_p/v)/\sin\theta$. | | | | | | | | | |
| <table border="0"> <thead> <tr> <th style="text-align: center;"><u>μ</u></th> <th style="text-align: center;"><u>Assessment</u></th> </tr> </thead> <tbody> <tr> <td style="text-align: center;">0.00 - 0.25</td> <td style="text-align: center;">Good</td> </tr> <tr> <td style="text-align: center;">0.26 - 0.35</td> <td style="text-align: center;">Fair</td> </tr> <tr> <td style="text-align: center;">> 0.35</td> <td style="text-align: center;">Marginal</td> </tr> </tbody> </table> | <u>μ</u> | <u>Assessment</u> | 0.00 - 0.25 | Good | 0.26 - 0.35 | Fair | > 0.35 | Marginal | |
| <u>μ</u> | <u>Assessment</u> | | | | | | | | |
| 0.00 - 0.25 | Good | | | | | | | | |
| 0.26 - 0.35 | Fair | | | | | | | | |
| > 0.35 | Marginal | | | | | | | | |
| H. Vehicle exit angle from the barrier shall not be more than 12 degrees. Within 100 ft plus the length of the test vehicle from the point of initial impact with the railing, the railing side of the vehicle shall move no more than 20 ft from the line of the traffic face of railing. | | | | | | | | | |

4 TEST RESULTS

4.1 Test No. KSCR-1

Test KSCR-1 was conducted with an 18,040 lb. GMC 7000 Series single unit truck. The actual impact conditions were 51.5 mph and 15 degrees. The location of impact was 5 ft downstream from Post No. 4, which was midway between Post No. 4 and Post No. 5. This location was determined to be the most critical section. A summary of the test results and sequential photos is shown in Figure 18. Additional sequential photos are shown in Figures 19, 20, and 21.

After the initial impact with the rail, the front right portion of the fender crushed inward. Approximately 0.15 sec after the initial impact with the rail, the front axle detached from the undercarriage on the passenger side of the vehicle. Then the cab began to ride up the rail. Following this series of events, the cab regained its position parallel to the rail at 0.34 sec, as the box began to rotate clockwise towards the rail. This shifting of the box forced the cab of the vehicle to follow the same motion and also rotate clockwise towards the rail in the same manner. At approximately 0.40 sec, when both the cab and box were rotated clockwise towards the rail, the vehicle was sliding parallel to the rail. As this sliding motion occurred, the rear end of the vehicle yawed away from the rail. This sequence of events can be seen in the parallel sequential photos (Figure 21).

A maximum roll angle of approximately 50 degrees was measured as the truck reached the downstream end of the rail (1.2 sec after impact). At this point the vehicle began to rotate counterclockwise toward the ground. The vehicle came to rest approximately 2.5 sec after impact. This location was 145 ft downstream from impact.

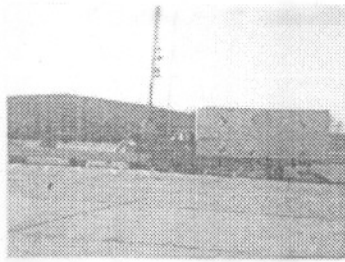

Impact

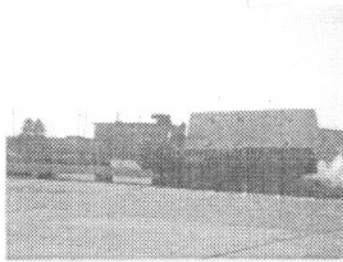

0.625 sec

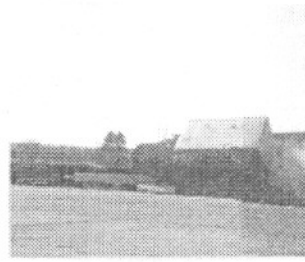

0.938 sec

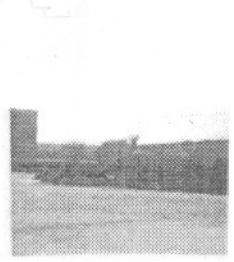

1.250 sec

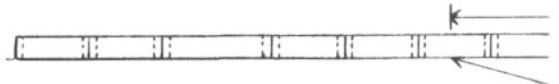

IMPACT

29

| | | | |
|-----------------------------|------------------------|------------------------------------|--|
| Test No. | KSCR-1 | Yht | |
| Date | 2/22/91 | Test Inertia (lb.) | |
| Installation | 32 in. Corral Rail | Gross Static (lb.) | |
| Total Length (ft) | 100 | VehSpeed | |
| Concrete Barrier | | ict (mph) | |
| Material | Nebraska Class | l(mph) | |
| | 47-B-Special Mix | VehAngle | |
| Concrete Rail | | ict (deg.) | |
| Length (ft) | 100 | (deg.) | |
| Width (in.) | 12 | Snag | |
| Height (in.) | | VehStability | |
| Top (in.) | 32 | Occit Impact Velocity | |
| Bottom (in.) | 13 | itudinal (fps) | |
| Concrete Posts | | ral (fps) | |
| Length (ft) | 3 | Occit Ridedown Decelerations | |
| Width (in.) | 10 | itudinal | |
| Height (in.) | 13 | ral (g's) | |
| Concrete Bridge Deck | | VehDamage | |
| Length (ft) | 100 |) | |
| Width (ft) | 5 | [. | |
| Height (in.) | 9 | VehRebound Distance (ft) | |
| Vehicle | | Brid&rail Damage | |
| Model | 1984 GMC (7000 Series) | | |

Figure 18. Test KSCR-1 Summary and Sequential Photographs

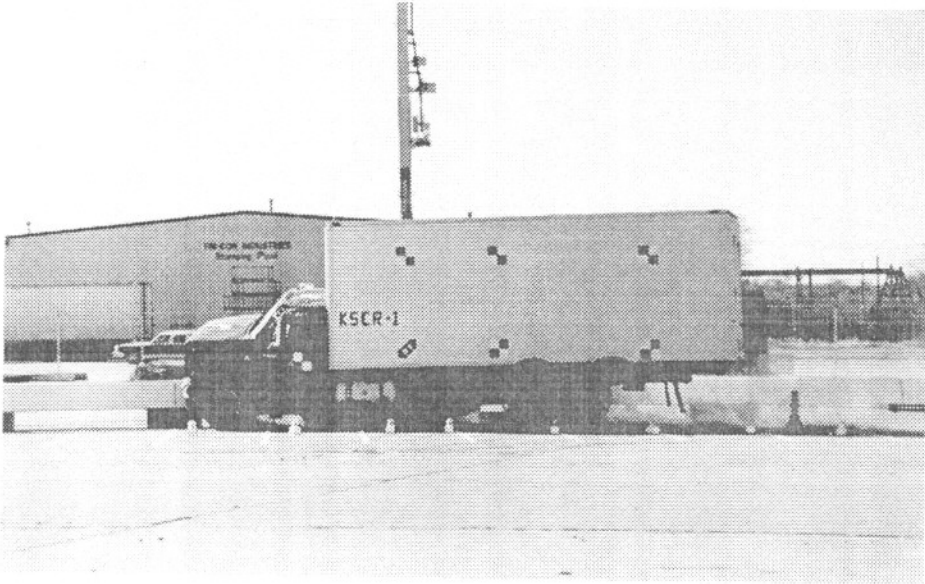
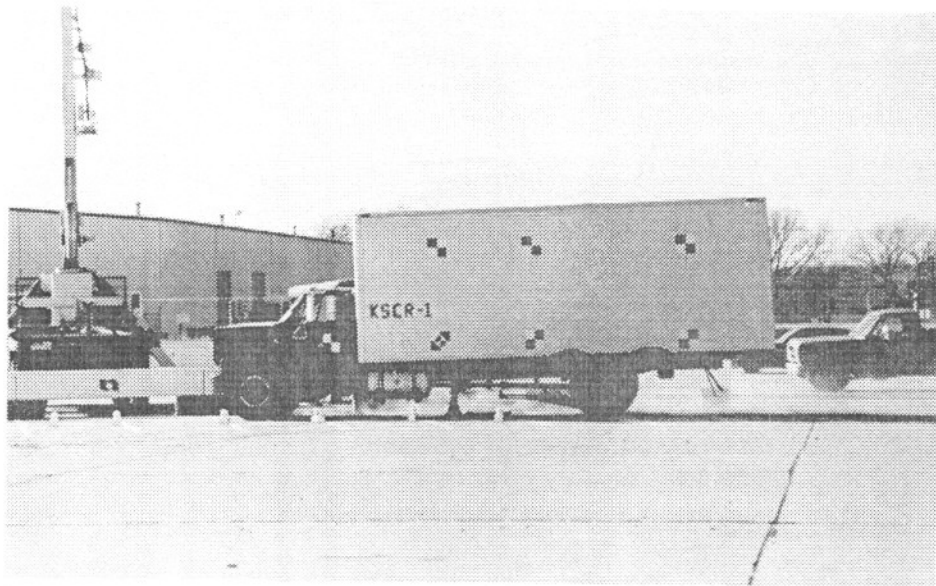

Figure 19. Full-Scale Vehicle Crash Test, KSCR-1

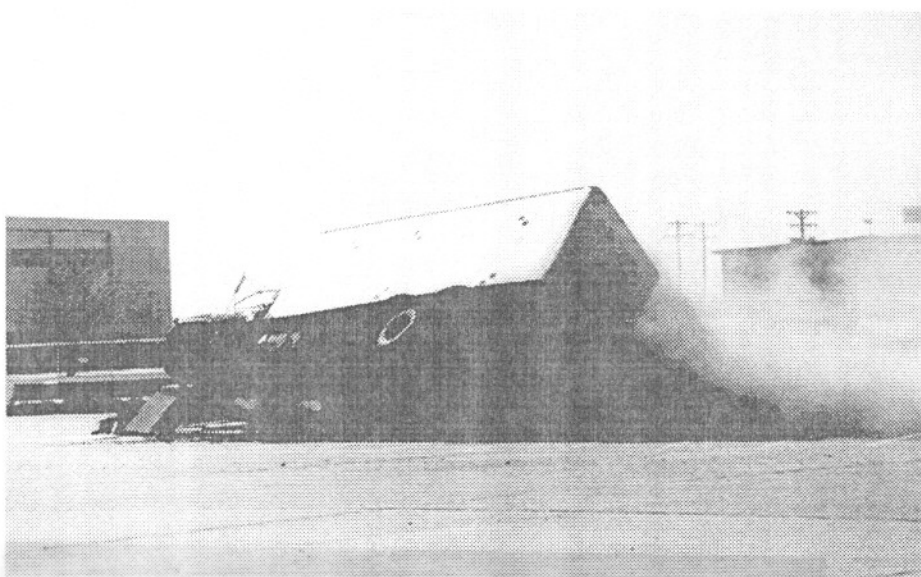
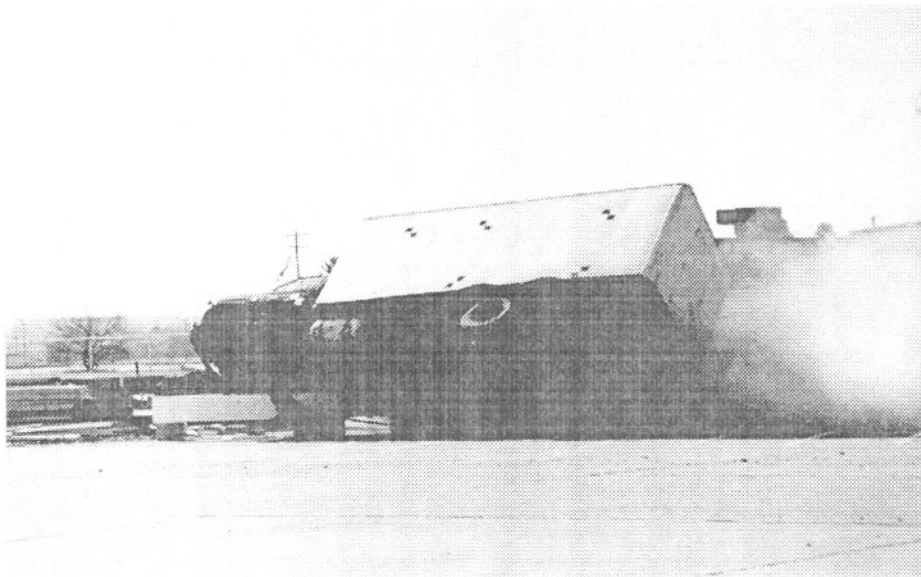
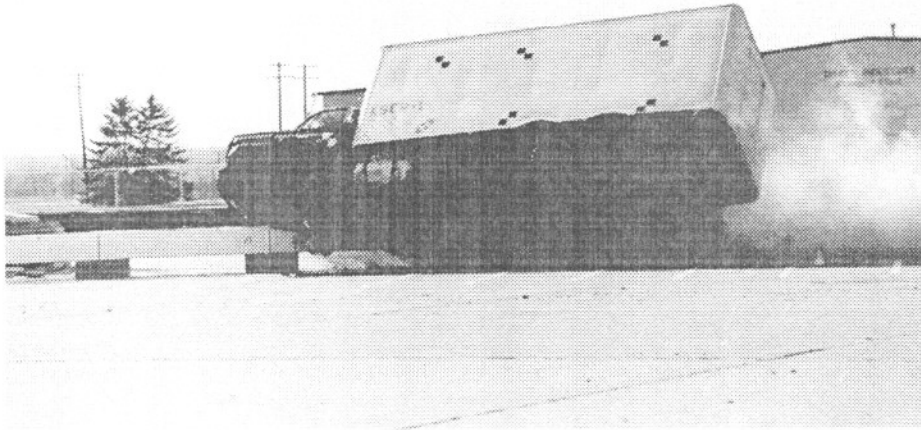
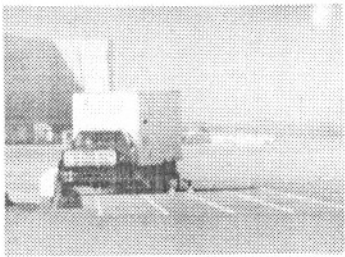
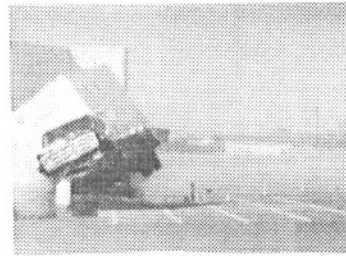

Figure 20. Full Scale Vehicle Crash Test, KSCR-1 (cont.)



Impact



0.520 sec

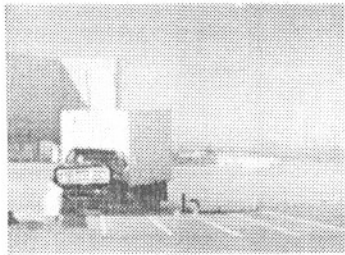

0.080 sec

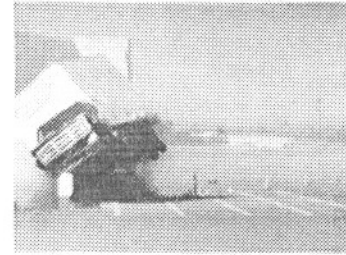

1.000 sec

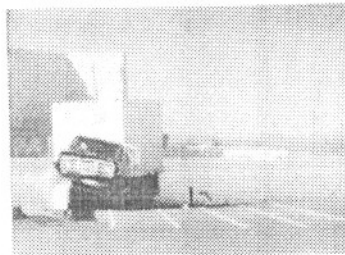

0.140 sec

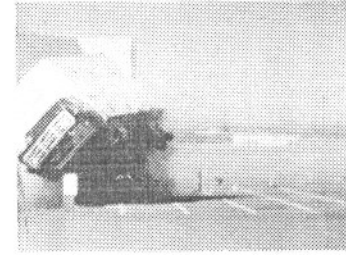

1.400 sec

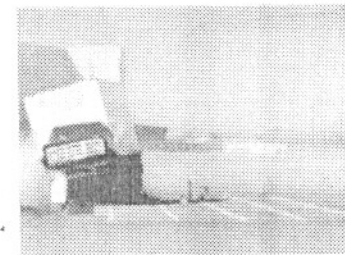

0.342 sec

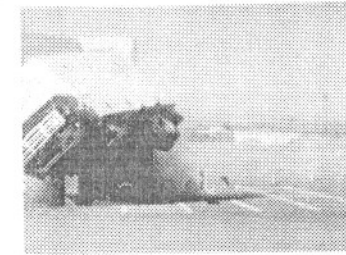

1.630 sec

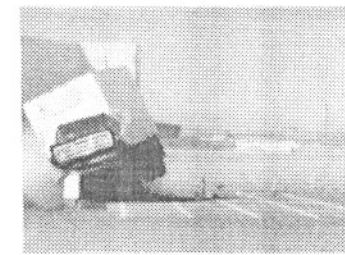

0.400 sec

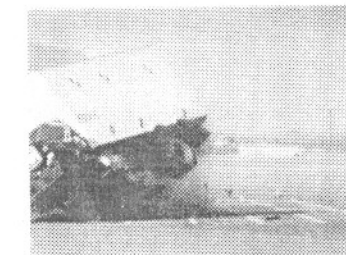

1.800 sec

Figure 21. Parallel Time-Sequential Photographs

the traffic face of the rail at post No. 5 is shown in Figure 24. The total amount of concrete that was removed from this failure was 18.5 in. wide, 19 in. high (entire rail height), and 5 in. deep. The same failure viewed from the backside of the rail is shown in Figure 25. This failure occurred before the gap in the rail at midpoint of Post No. 5. A vertical crack in the deck also occurred near the location of the post on the upstream end. Deck cracking also occurred at post No. 4. These deck cracks continued underneath the deck to the support.

The third major damage area resulted from the vehicle riding along the rail (Figure 26). Spalling and concrete chipping occurred continuously until the end of the rail. This damage occurred to the traffic face, the top and the back face of the rail.

The vehicle damage is shown in Figure 27. The damage included crushing of the passenger side bumper and grill. The front wheels and axle were totally removed from their original position and ended up lodged underneath the truck which may have contributed to the damage was minimal. The TAD (5) and VDI (6) damage classifications are shown in Figure 18.

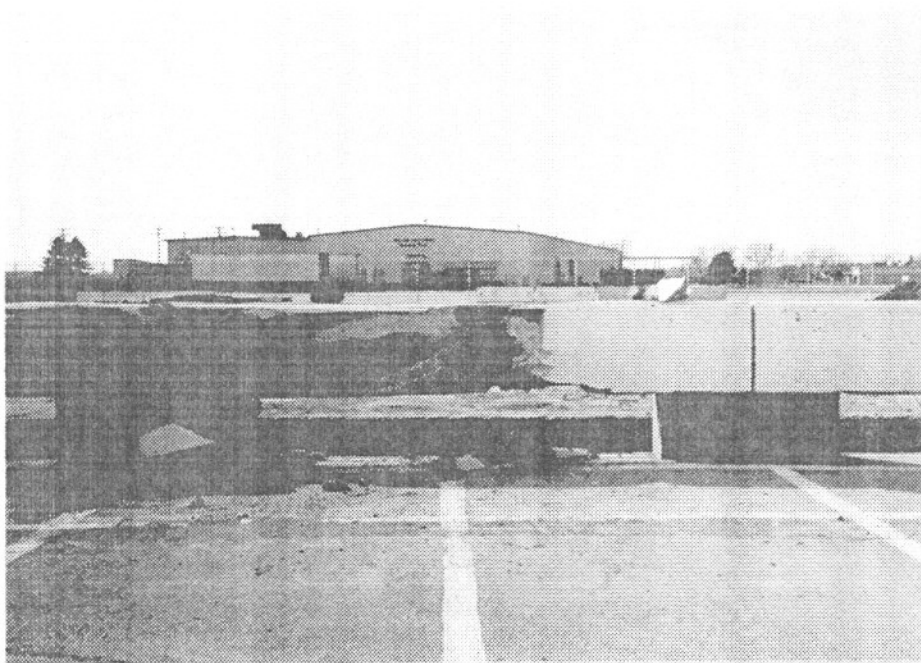
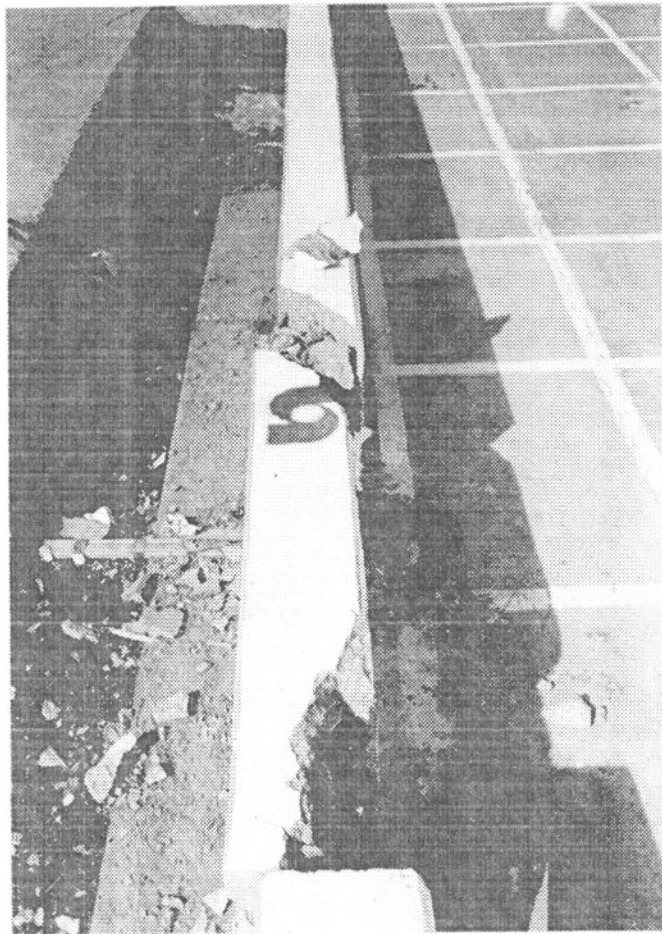

Figure 22. Rail Damage Between Posts No. 4 and No. 5

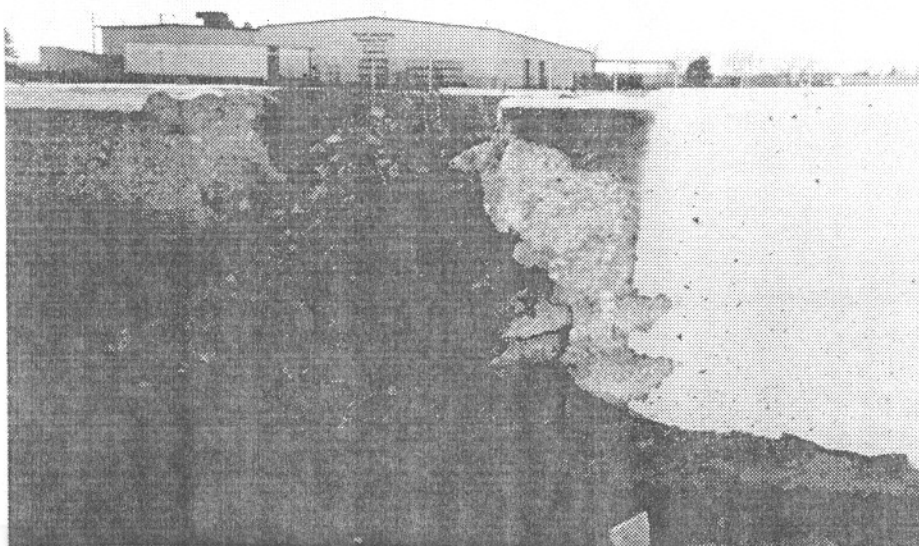
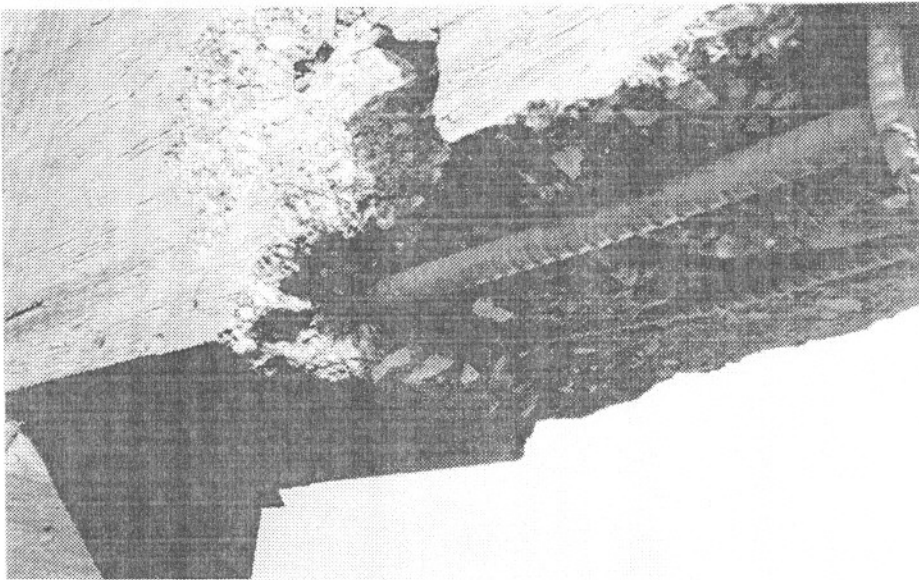
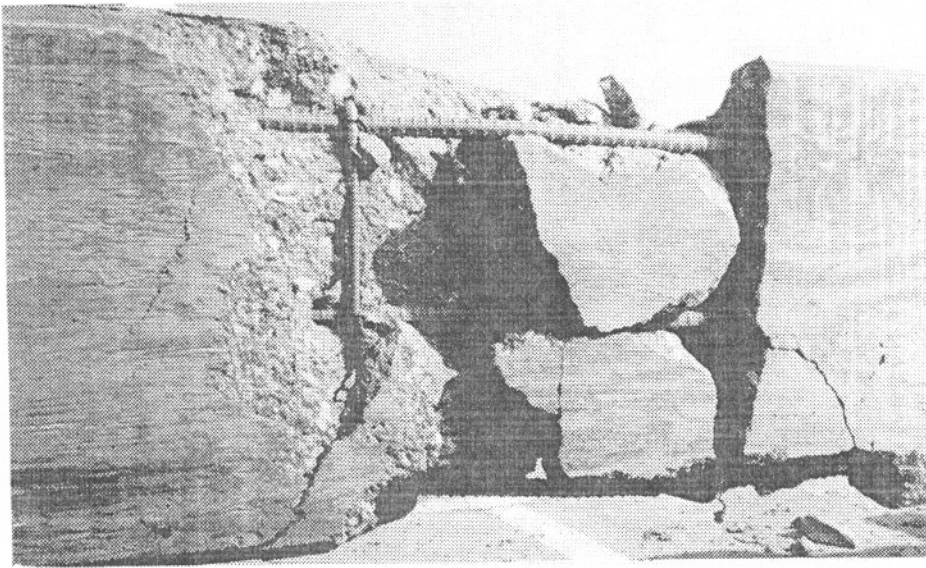

Figure 23. Rail Damage at point of impact

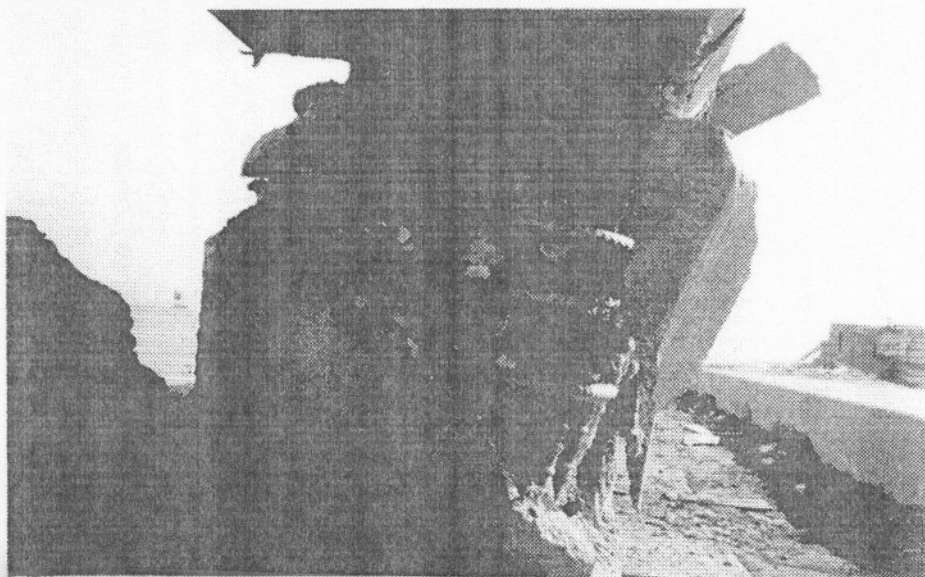
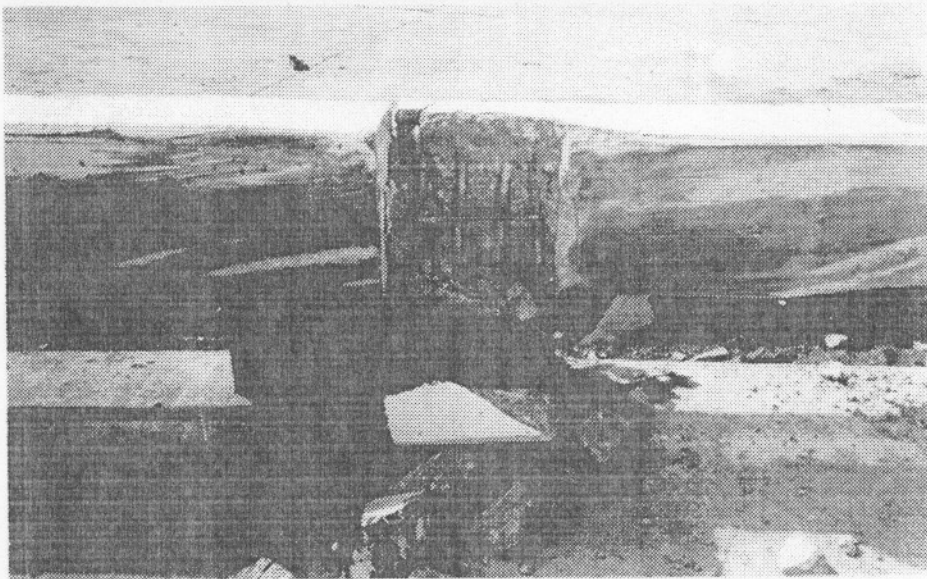

Figure 24. Rail and Post damage at Post No. 5

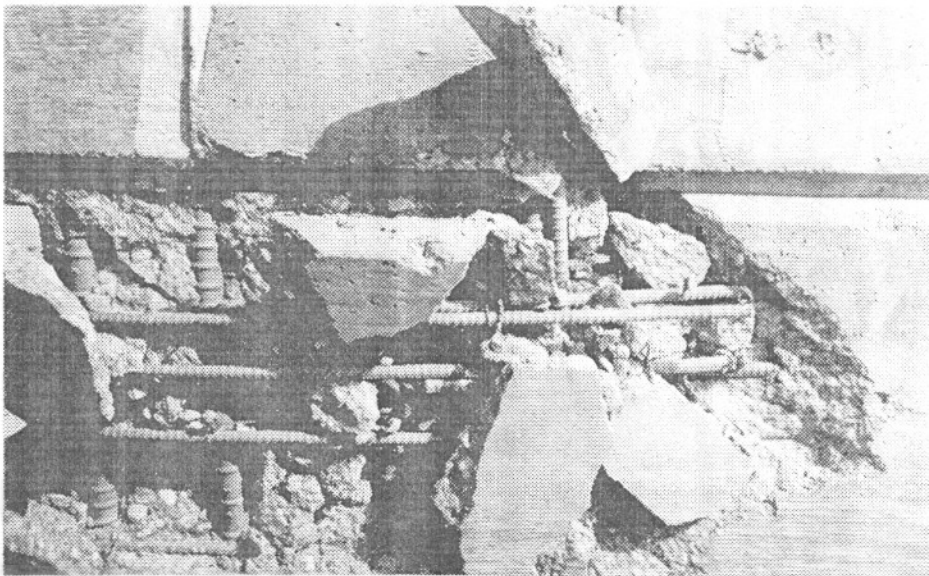
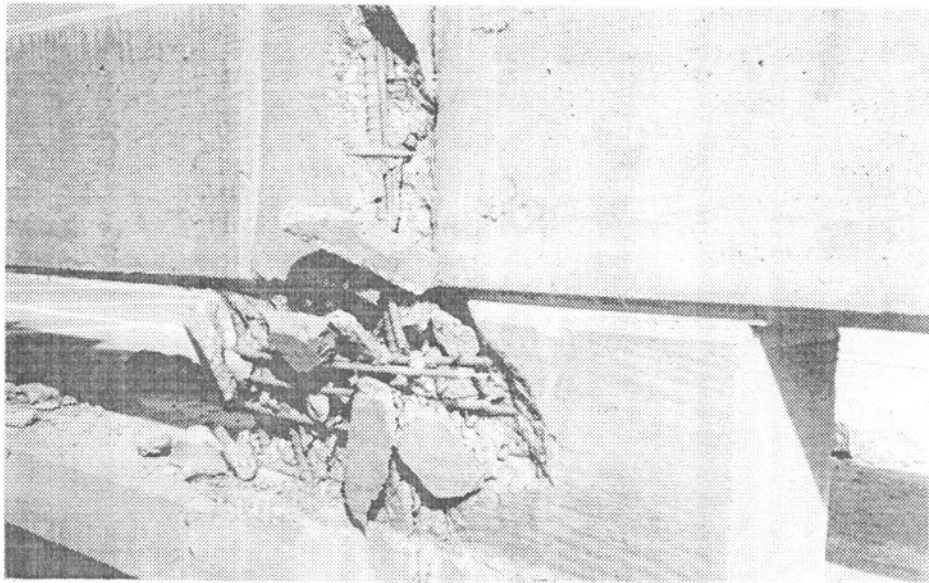
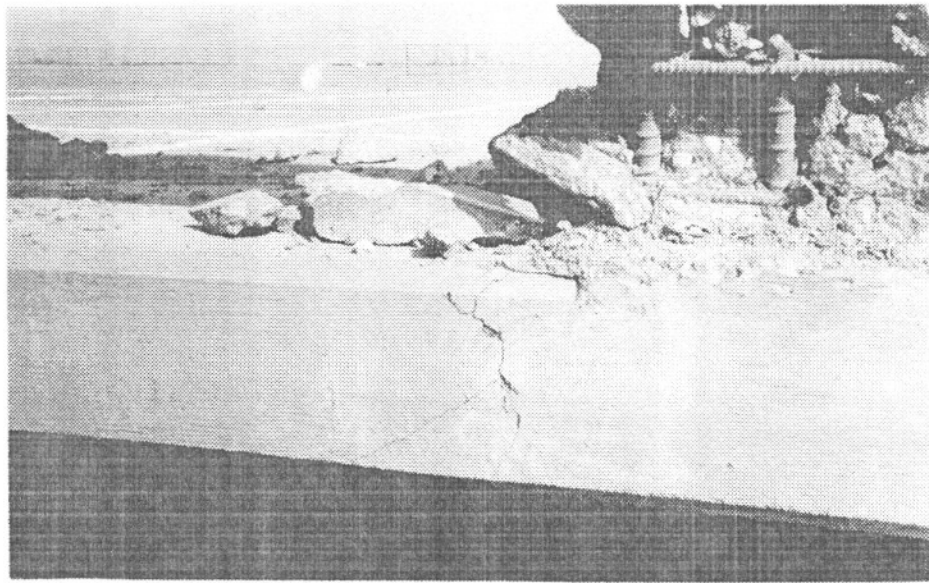

Figure 25. Post No. 5 damage at splice and deck cracking

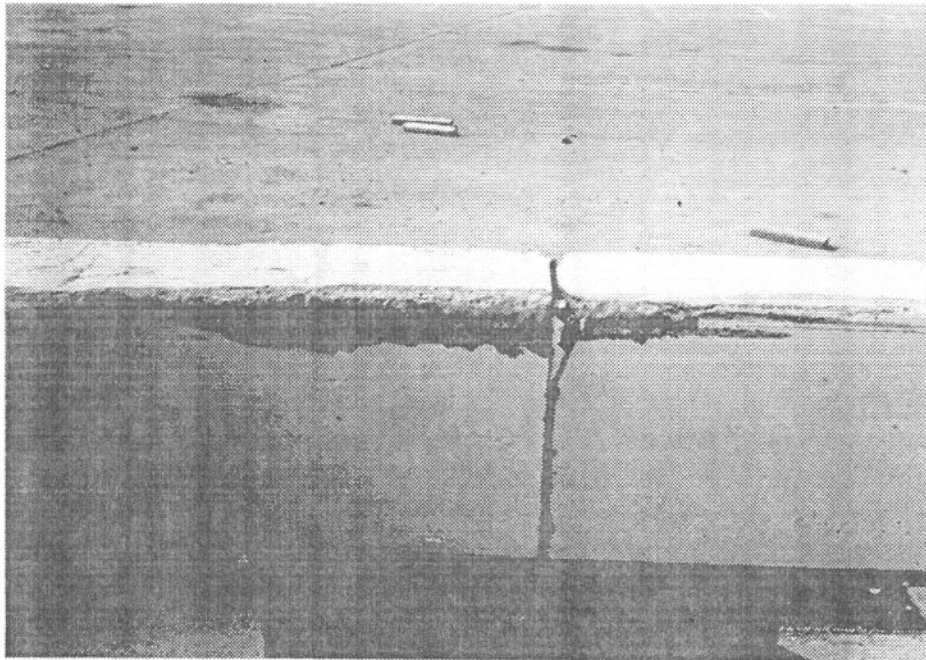
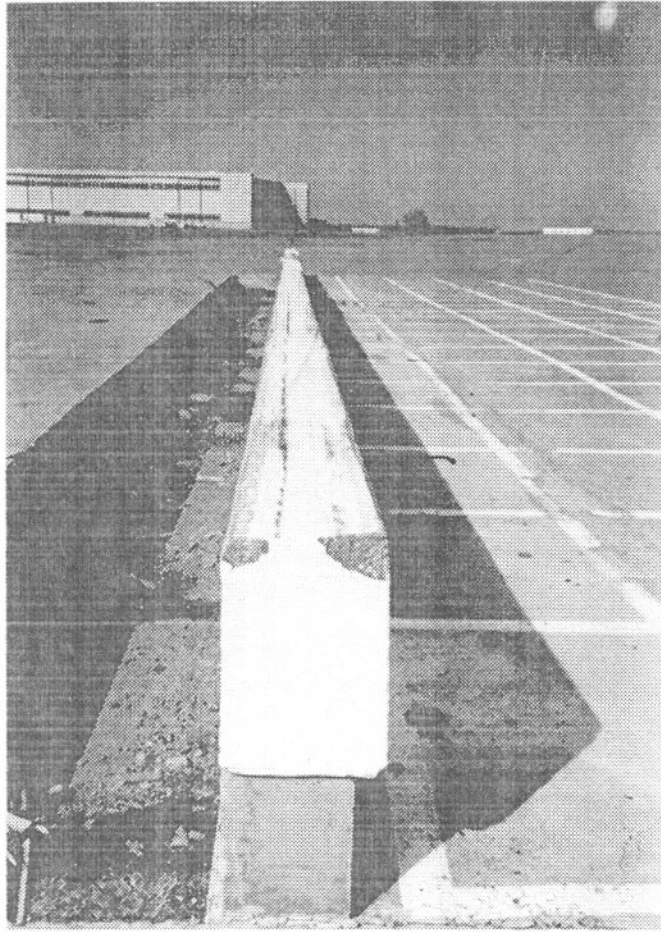

Figure 26. Damage from vehicle riding along the rail



Figure 27. Vehicle Damage

The longitudinal occupant impact velocity was determined to be 15.0 fps and the lateral occupant impact velocity was 10.0 fps. The longitudinal occupant ridedown deceleration was 6.1 g's and lateral occupant ridedown deceleration was 1.4 g's. The determination of these results using longitudinal and lateral accelerometer data is shown graphically in Appendix C. The results are also summarized in Figure 18 and in Table 4.

5 CONCLUSIONS

One full-scale crash test was conducted to evaluate the safety performance of the Kansas 32 in. Corral Rail. The test was conducted with a 1984 7000 Series GMC single unit truck weighing 18,040 lbs. with an impact angle and velocity of 15 degrees and 51.5 mph, respectively.

The test was evaluated according to the safety performance criteria given in AASHTO (1). The safety evaluation summary using this set of criteria is presented in Table 3. The results of the test are summarized in Table 4.

The analysis of the crash test revealed the following:

1. The concrete rail did successfully contain the vehicle.
2. Neither the vehicle nor its cargo penetrated or went over the installation.
3. No detached elements or fragments penetrated the passenger compartment.
4. The integrity of the passenger compartment was maintained.
5. The test vehicle remained upright during and after the collision.
6. The test article did smoothly redirect the vehicle.
7. The vehicles exit angle of 0 degrees was less than the limit of 12 degrees.

Based upon the items listed above, the results of Test KSCR-1 are acceptable according to the AASHTO (1) guidelines.

Table 3. Safety Performance Results

| EVALUATION CRITERIA | RESULTS | | | | | | | | |
|---|-------------------------|-------------------|-------------|------|-------------|------|--------|----------|---|
| REQUIRED | | | | | | | | | |
| A. The test article shall contain the vehicle; neither the vehicle nor its cargo shall penetrate or go over the installation. Controlled lateral deflection of the test article is acceptable. | S | | | | | | | | |
| B. Detached elements, fragments or other debris from the test article shall not penetrate or show potential for penetrating the passenger compartment or present undue hazard to other traffic. | S | | | | | | | | |
| C. Integrity of the passenger compartment must be maintained with no intrusion and essentially no deformation. | S | | | | | | | | |
| DESIRABLE | | | | | | | | | |
| D. The vehicle shall remain upright during and after collision. | S | | | | | | | | |
| E. The test article shall smoothly redirect the vehicle. A redirection is deemed smooth if the rear of the vehicle does not yaw more than 5 degrees away from the railing from time of impact until the vehicle separates from the railing. | S | | | | | | | | |
| F. The smoothness of the vehicle-railing interaction is further assessed by the effective coefficient of friction, μ , where $\mu = (\cos\theta - V_p/v)/\sin\theta$. <table style="margin-left: auto; margin-right: auto; border-collapse: collapse;"> <tr> <td style="text-align: center;"><u>μ</u></td> <td style="text-align: center;"><u>Assessment</u></td> </tr> <tr> <td style="text-align: center;">0.00 - 0.25</td> <td style="text-align: center;">Good</td> </tr> <tr> <td style="text-align: center;">0.26 - 0.35</td> <td style="text-align: center;">Fair</td> </tr> <tr> <td style="text-align: center;">> 0.35</td> <td style="text-align: center;">Marginal</td> </tr> </table> | <u>μ</u> | <u>Assessment</u> | 0.00 - 0.25 | Good | 0.26 - 0.35 | Fair | > 0.35 | Marginal | * |
| <u>μ</u> | <u>Assessment</u> | | | | | | | | |
| 0.00 - 0.25 | Good | | | | | | | | |
| 0.26 - 0.35 | Fair | | | | | | | | |
| > 0.35 | Marginal | | | | | | | | |
| H. Vehicle exit angle from the barrier shall not be more than 12 degrees. Within 100 ft plus the length of the test vehicle from the point of initial impact with the railing, the railing side of the vehicle shall move no more than 20 ft from the line of the traffic face of railing. | S | | | | | | | | |

S - Satisfactory M - Marginal U - Unsatisfactory G - Good

* The vehicle never became parallel to the barrier so the coefficient of friction could not be calculated.

Table 4. Summary of Test Results

| Test Item | Result |
|---|---------|
| Vehicle Weight (lb.) | 18,040 |
| Vehicle Impact Speed (mph) | 51.5 |
| Vehicle Exit Speed (mph) | 27.0 |
| Vehicle Impact Angle (deg.) | 15.0 |
| Vehicle Exit Angle (deg.) | 0.0 |
| Vehicle Rebound Distance (ft) | 0 |
| Vehicle Damage (TAD) (7) | 1-RFQ-4 |
| Vehicle Damage (VDI) (8) | 01RFES1 |
| Longitudinal Occupant Impact Velocity (fps) | 15.0 |
| Lateral Occupant Impact Velocity (fps) | 10.0 |
| Longitudinal Occupant Ridedown Deceleration (g's) | 6.1 |
| Lateral Occupant Ridedown Deceleration (g's) | 1.4 |
| Did snagging occur? | No |
| Did vehicle remain upright? | Yes |

6 RECOMMENDATIONS

The Kansas Corral Rail has met the criteria for all three of the vehicle classifications of the PL-2 performance level in the AASHTO guide specifications (1).

Therefore, it is recommended that the Federal Highway Administration approve this appurtenance as a safe design and qualify it for use on Federal Aid Projects.

7 REFERENCES

1. "Guide Specifications for Bridge Railings," American Association of State Highways and Transportation Officials, Washington, D.C., 1989.
2. "Bridge Rail Designs and Performance Standards", Volume 1: Research Report, Federal Highway Administration Report No. FHWA/RD-87/049, February 1987.
3. "Recommended Procedures for the Safety Performance Evaluation of Highway Appurtenances," National Cooperative Highway Research Program Report 230, Transportation Research Board, Washington, D.C., March, 1981.
4. Hinch, J., Yang, T-L, and Owings, R., "Guidance Systems for Vehicle Testing," ENSCO, Inc., Springfield, VA, 1986.
5. "Vehicle Damage Scale for Traffic Accident Investigators," Traffic Accident Data Project Technical Bulletin No. 1, National Safety Council, Chicago, IL, 1971.
6. "Collision Deformation Classification, Recommended Practice J224 March 80," SAE Handbook Vol. 4, Society of Automotive Engineers, Warrendale, Penn., 1985.

8 APPENDICES

APPENDIX A.
CONCRETE COMPRESSIVE STRENGTHS

REPORT OF CONCRETE CORES

UNIVERSITY OF NEBRASKA BARRIER TESTING

Project: Kansas Bridge Crash Test

Examined For: Compressive Strength

| Date | | Location | Strength - PSI |
|----------|----------|-------------|----------------|
| Placed | Tested | | |
| 10-26-90 | 10-30-90 | Bridge Deck | 4490 |
| 10-26-90 | 11-26-90 | Bridge Deck | 5360 * |
| 12-11-90 | 12-18-90 | Bridge Rail | 3760 |
| 12-11-90 | 2-7-90 | Bridge Rail | 4560 |

* Core taken at 4 days age and cured in laboratory until tested

Remarks: The bridge deck cores were taken at 4 days of age and cured in the lab. The bridge rail cores were taken 1 day prior to testing.



Dalyce Ronnau
Engineer for Research & Tests

For NDOR Materials & Tests Division

APPENDIX B.
RELEVANT CORRESPONDENCE

August 15, 1990

TO: State Highway Departments of Nebraska, Kansas, and Missouri

FROM: Midwest Roadside Safety Facility, Civil Engineering
Department, University of Nebraska-Lincoln

SUBJECT: Research Proposal For The Midwest Regional Pooled Fund
Program (Year 1)

The Midwest Roadside Safety Facility (MwRSF) proposes to conduct six full-scale vehicle crash tests using three different concrete bridge rail systems for a total of \$, as shown in Table 1. This includes two 18,000 lb., one 1,800 lb., and three 5,400lb. vehicle tests.

The three systems which will be constructed, removed, and disposed are as follows:

- (1) the 30" high barrier rail (Missouri)
- (2) the open concrete rail (Nebraska)
- (3) the 32" high corral rail (Kansas)

The estimated construction, removal, etc., costs were determined from the preliminary provided plans. The preliminary work schedule is shown in Table 2.

MISSOURI

Three full-scale vehicle crash tests are required to satisfy the PL-2 Performance Level on the 30" high barrier rail.

NEBRASKA

The open concrete rail was previously tested under NCHRP 230 (FHWA/RD-89-119), but, a modification using less reinforcement would require the 5,400 lb. test at the expansion joint to satisfy the PL-1 Performance Level. An 1,800 lb. vehicle test would not be required. If a failed performance evaluation would occur, a redesign would follow, along with a 5,400 lb. test.

The previous testing was conducted at ENSCO consisting of a 29" high, open concrete rail. The results of the tests are as follows:

Test 1769-F-1-86: 4,669 lb. test vehicle
57.6 mph and 26 degrees
barrier contact - 11 ft.
impact velocity (fps) - (accelerometer)
longitudinal ...17.2 <30 ok
lateral31.2 >20 ?
ridgedown acceleration (g's) - (accel.)
longitudinal ...-2.8 <15 ok
lateral-14.3 <15 ok

Test 1769-F-2-86: 1,971 lb. test vehicle
59.8 mph and 21 degrees
barrier contact - 12 ft.
impact velocity (fps) - (accelerometer)
 longitudinal ...21.8 <30 ok
 lateral24.1 >20 ?
ridedown acceleration (g's) - (accel.)
 longitudinal ...-4.9 <15 ok
 lateral-10.5 <15 ok

KANSAS

A 27" high corral rail was previously tested under NCHRP 230 (FHWA/RD-87-049) which was cited as a basis for not requiring the 1,800 lb. and 5,400 lb. vehicle tests. Thus, only an 18,000 lb. vehicle test is required to satisfy the PL-2 Performance Level.

The previous testing was conducted at Southwest Research Institute consisting of two designs, (1) the KBR Series and (2) the MKS Series. The KBR Series consisted of the 27" high, Kansas corral rail without curb. The MKS Series comes from a modification to the Kansas corral rail due to an addition of longitudinal beam steel and stirrups in both the beam and posts. The results of the MKS Series are as follows:

Test MKS-1: 1,850 lb. test vehicle
59.0 mph and 18.9 degrees
barrier contact - 7.8 ft.
impact velocity (fps) - (film/accelerometer)
 longitudinal ... 9.2/14.0 <30 ok
 lateral19.5/18.2 <20 ok
ridedown acceleration (g's) - (accelerometer)
 longitudinal ... 1.4 <15 ok
 lateral-14.8 <15 ok

Test MKS-2: 4,690 lb. test vehicle
59.2 mph and 24.9 degrees
barrier contact - 12.2 ft.
impact velocity (fps) - (film/accelerometer)
 longitudinal ... 6.7/13.9 <30 ok
 lateral19.3/24.9 <20 ok
ridedown acceleration (g's) - (accelerometer)
 longitudinal ...-1.7 <15 ok
 lateral-13.9 <15 ok

APPENDIX C.

ACCELEROMETER DATA ANALYSIS

| | Page |
|---|------|
| C-1 Sketch of Accelerometer Locations | 53 |
| C-2 Graph of Longitudinal Deceleration, Acc. #2 | 54 |
| C-3 Graph of Longitudinal Occupant Impact Velocity, Acc. #2 | 55 |
| C-4 Graph of Longitudinal Occupant Displacement, Acc. #2 | 56 |
| C-5 Graph of Lateral Deceleration, Acc. #3 | 57 |
| C-6 Graph of Lateral Occupant Impact Velocity, Acc. #3 | 58 |
| C-7 Graph of Lateral Occupant Displacement, Acc. #3 | 59 |
| C-8 Graph of Lateral Deceleration, Acc. #4 | 60 |
| C-9 Graph of Lateral Occupant Impact Velocity, Acc. #4 | 61 |
| C-10 Graph of Lateral Occupant Displacement, Acc. #4 | 62 |

↑
FRONT OF
VEHICLE

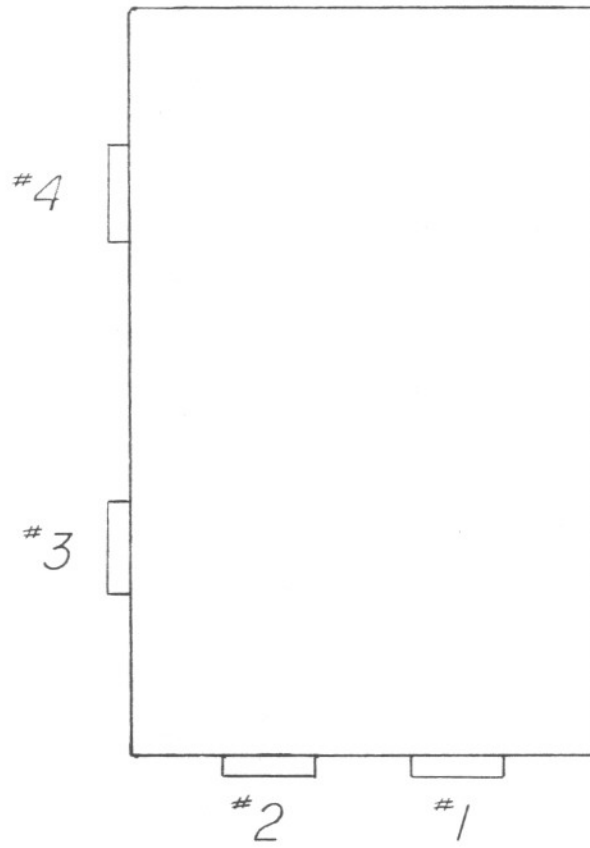

C-1 Sketch of Accelerometer Locations

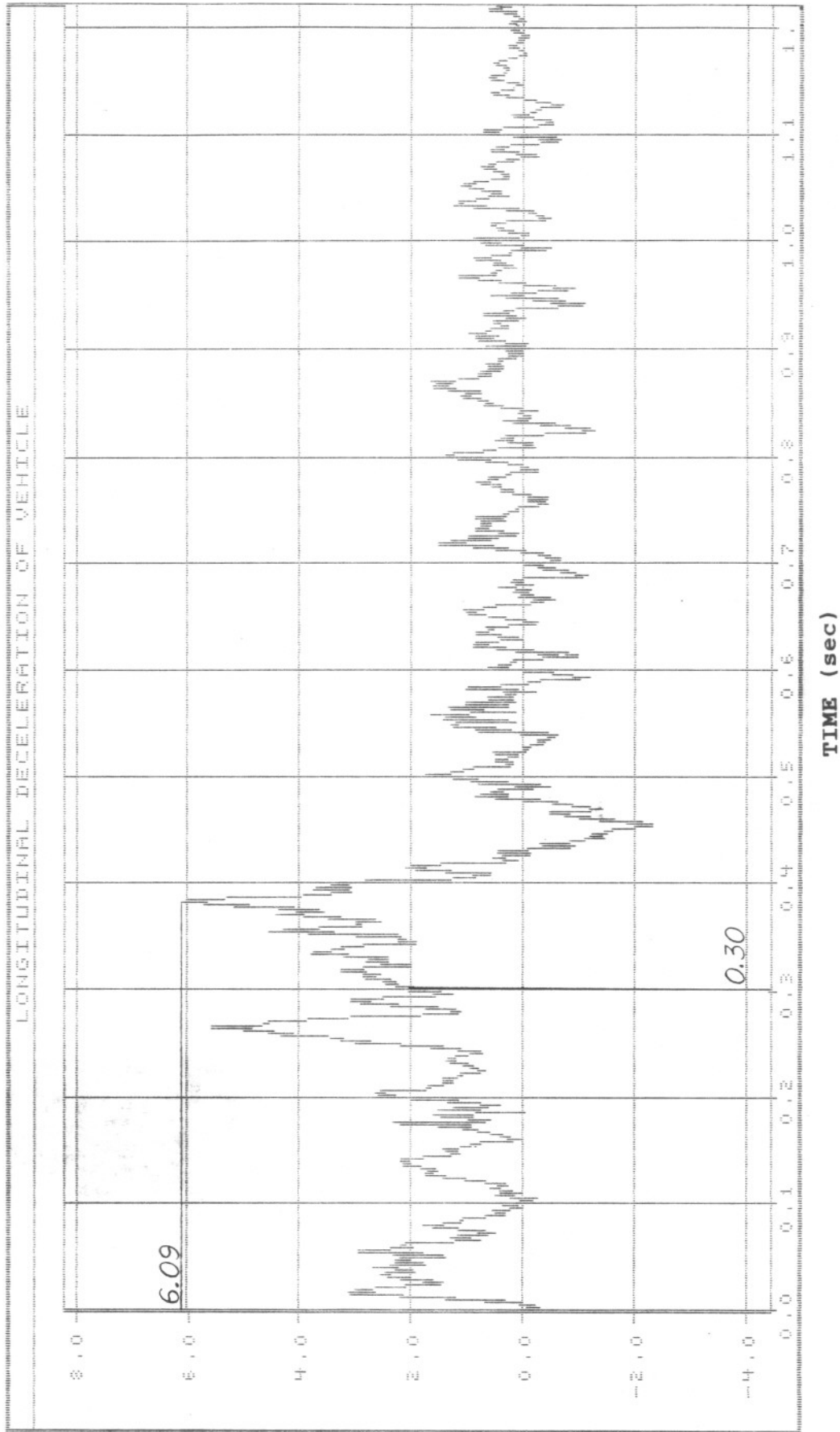
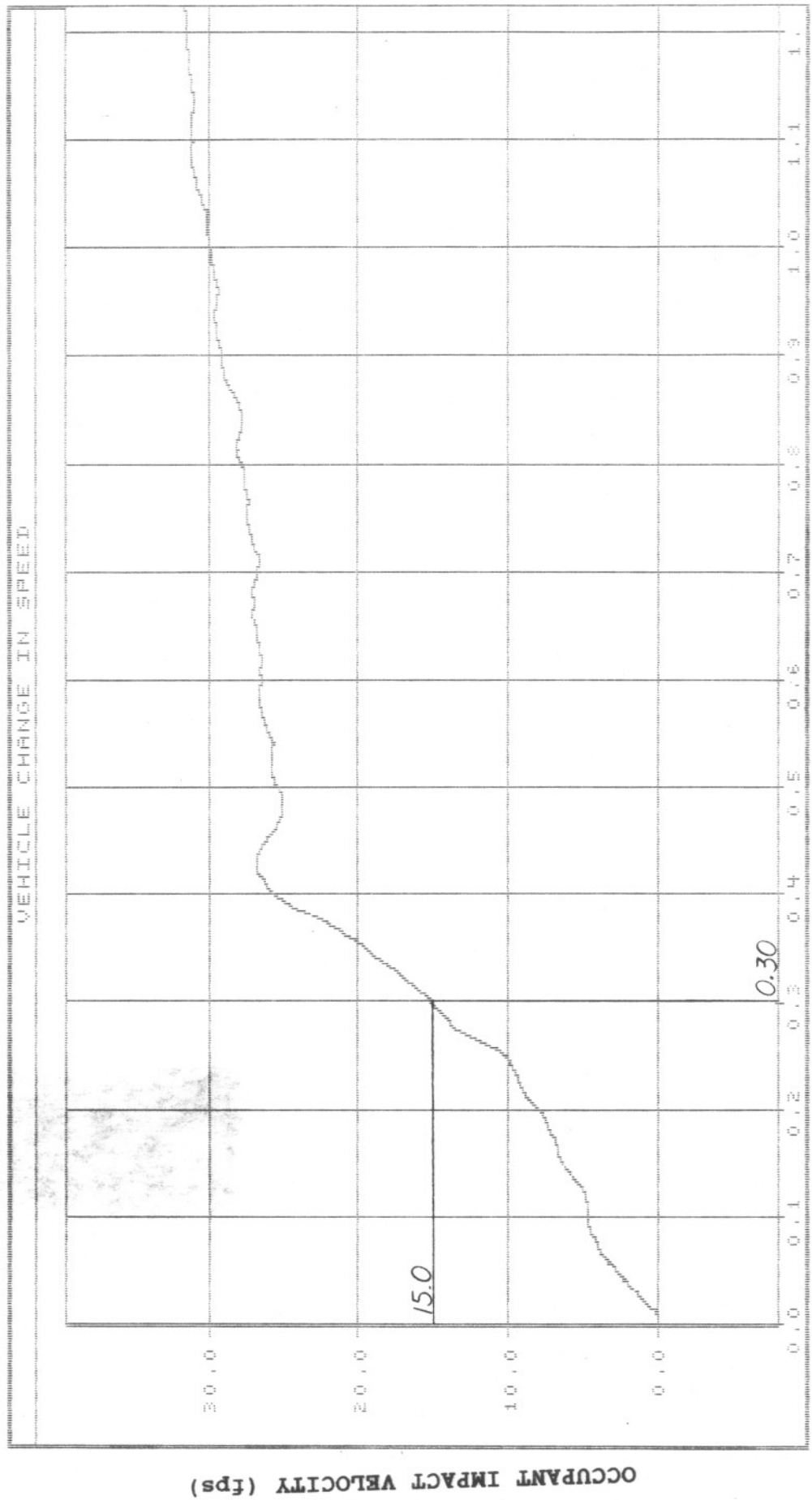

FIGURE C-2. GRAPH OF LONGITUDINAL DECELERATION, ACC. #2



TIME (sec)

$$(\Delta V)^* = (\Delta V) \frac{(V \sin \theta)_{target}}{(V \sin \theta)_{actual}} = \frac{15.0 (73.5 \sin 15^\circ)}{(75.71 \sin 15^\circ)}$$

$$(\Delta V)^* = 14.56 \text{ fps}$$

FIGURE C-3. GRAPH OF LONGITUDINAL OCCUPANT IMPACT VELOCITY, ACC. #2

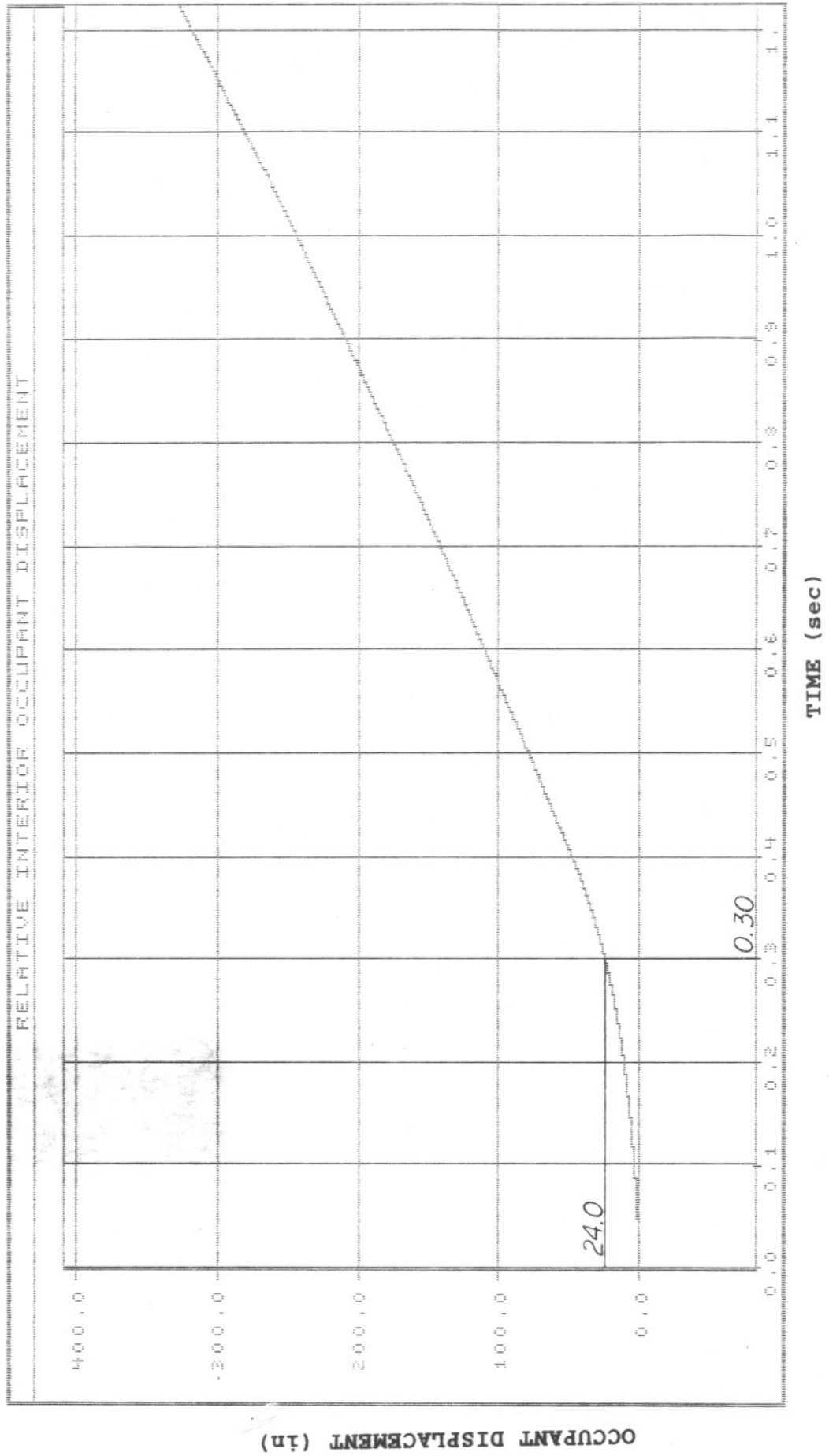

FIGURE C-4. GRAPH OF LONGITUDINAL OCCUPANT DISPLACEMENT, ACC. #2

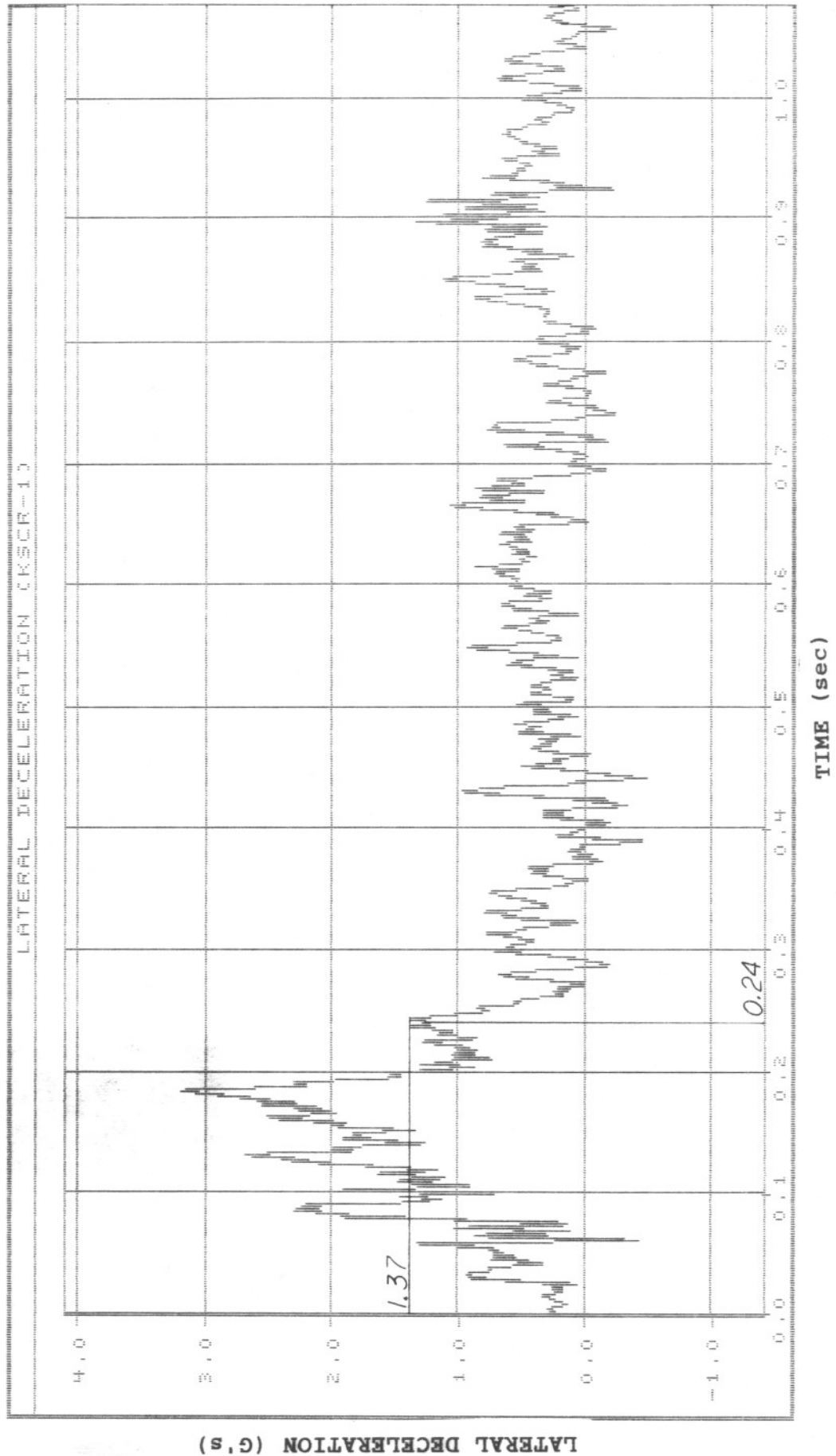
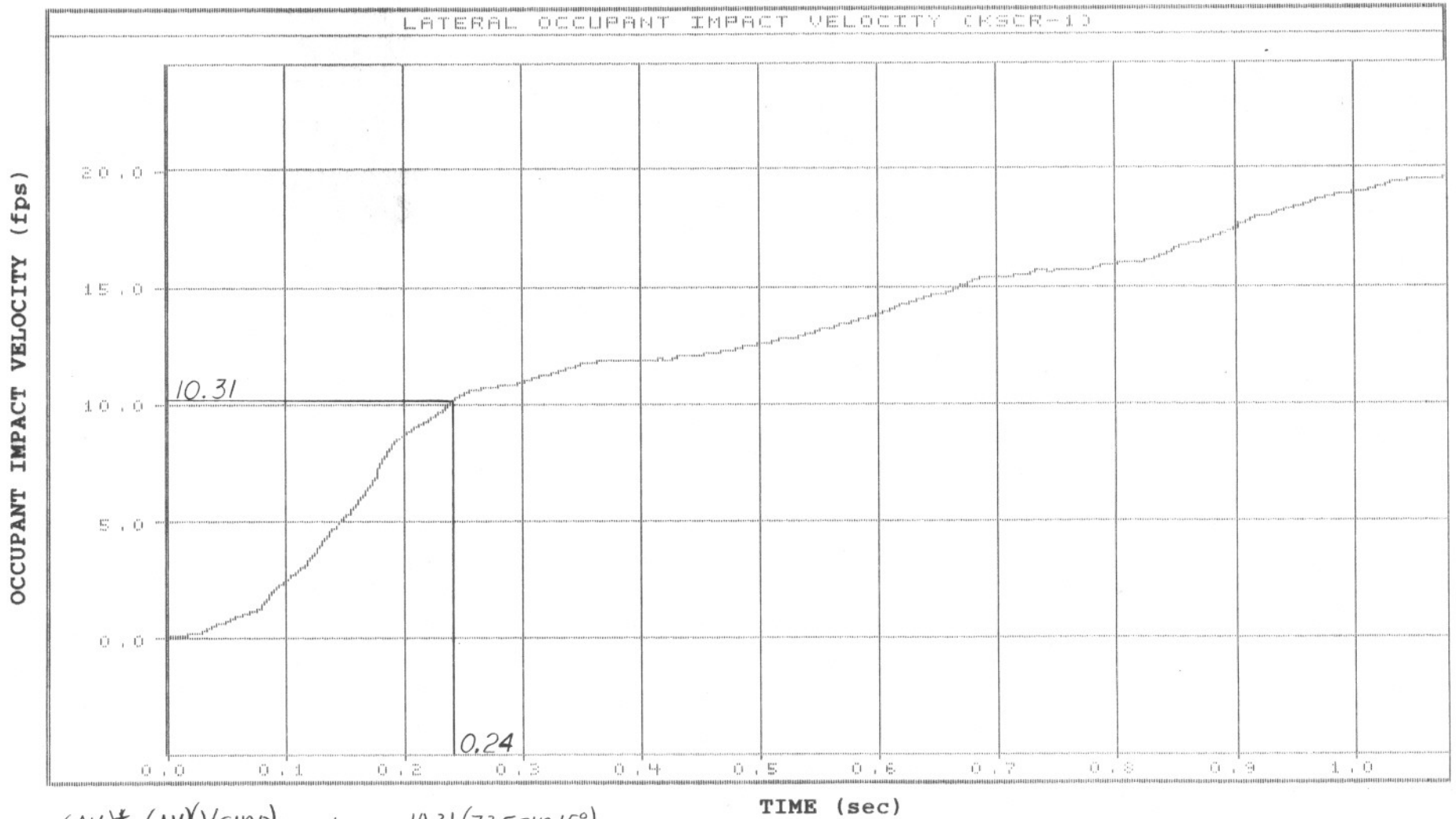

FIGURE C-5. GRAPH OF LATERAL DECELERATION, ACC. #3



$$(\Delta V)^* = \frac{(\Delta V)(V \sin \theta)_{\text{target}}}{(V \sin \theta)_{\text{actual}}} = \frac{10.31 (73.5 \sin 15^\circ)}{(75.71 \sin 15^\circ)}$$

$$(\Delta V)^* = 10.0 \text{ fps}$$

FIGURE C-6. GRAPH OF LATERAL OCCUPANT IMPACT VELOCITY, Acc. #3

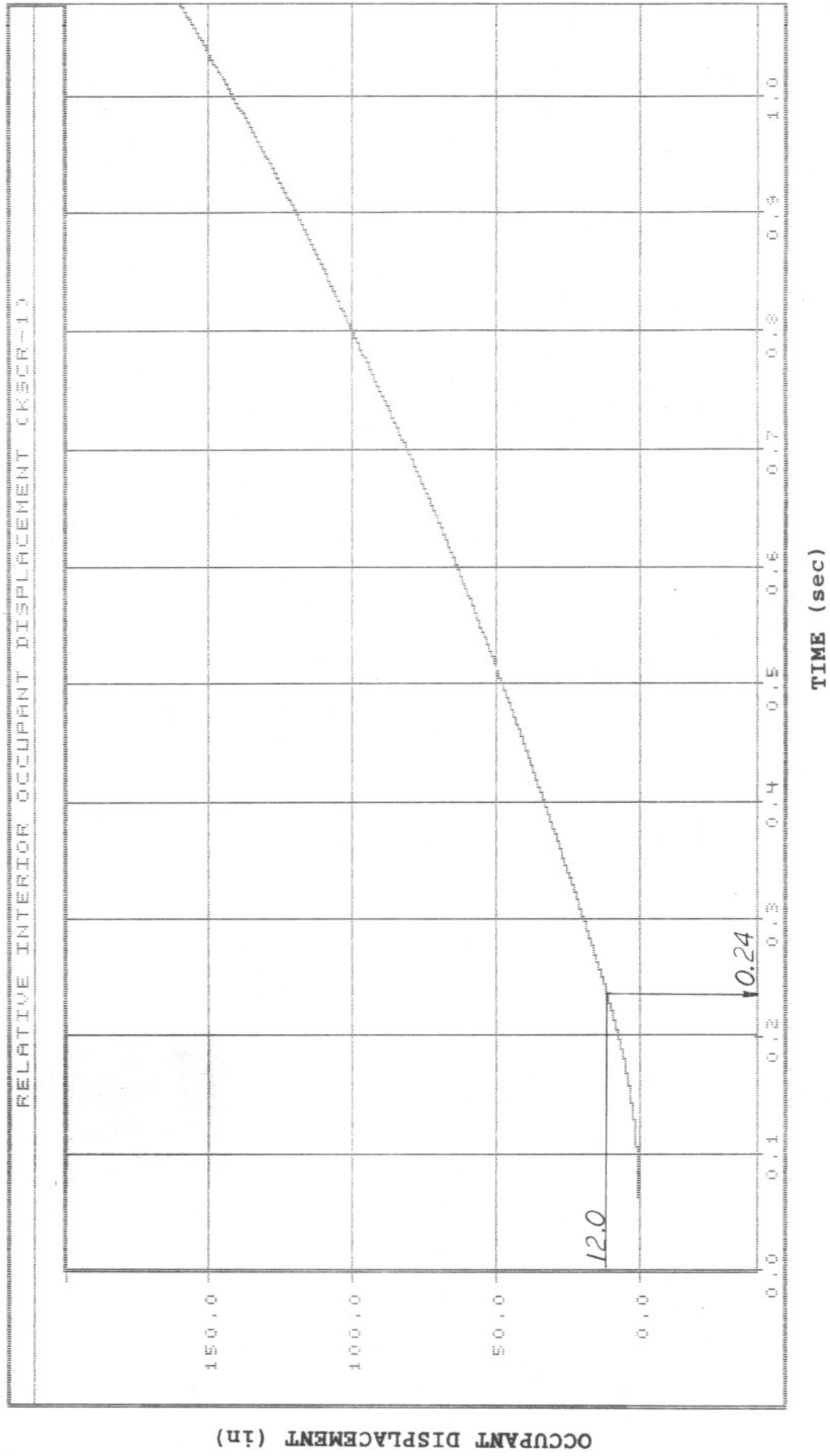

FIGURE C-7. GRAPH OF LATERAL OCCUPANT DISPLACEMENT, ACC. #3

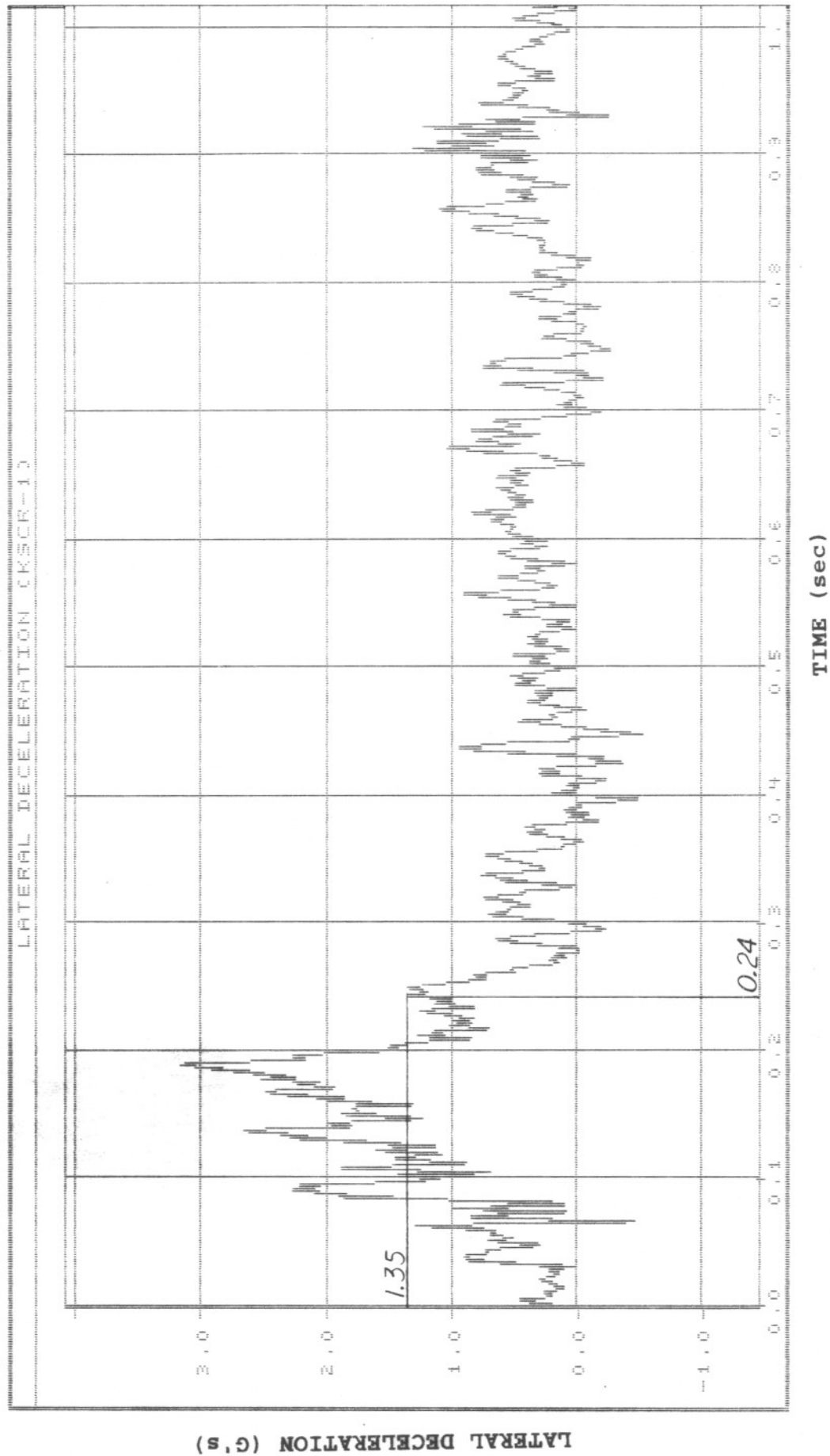
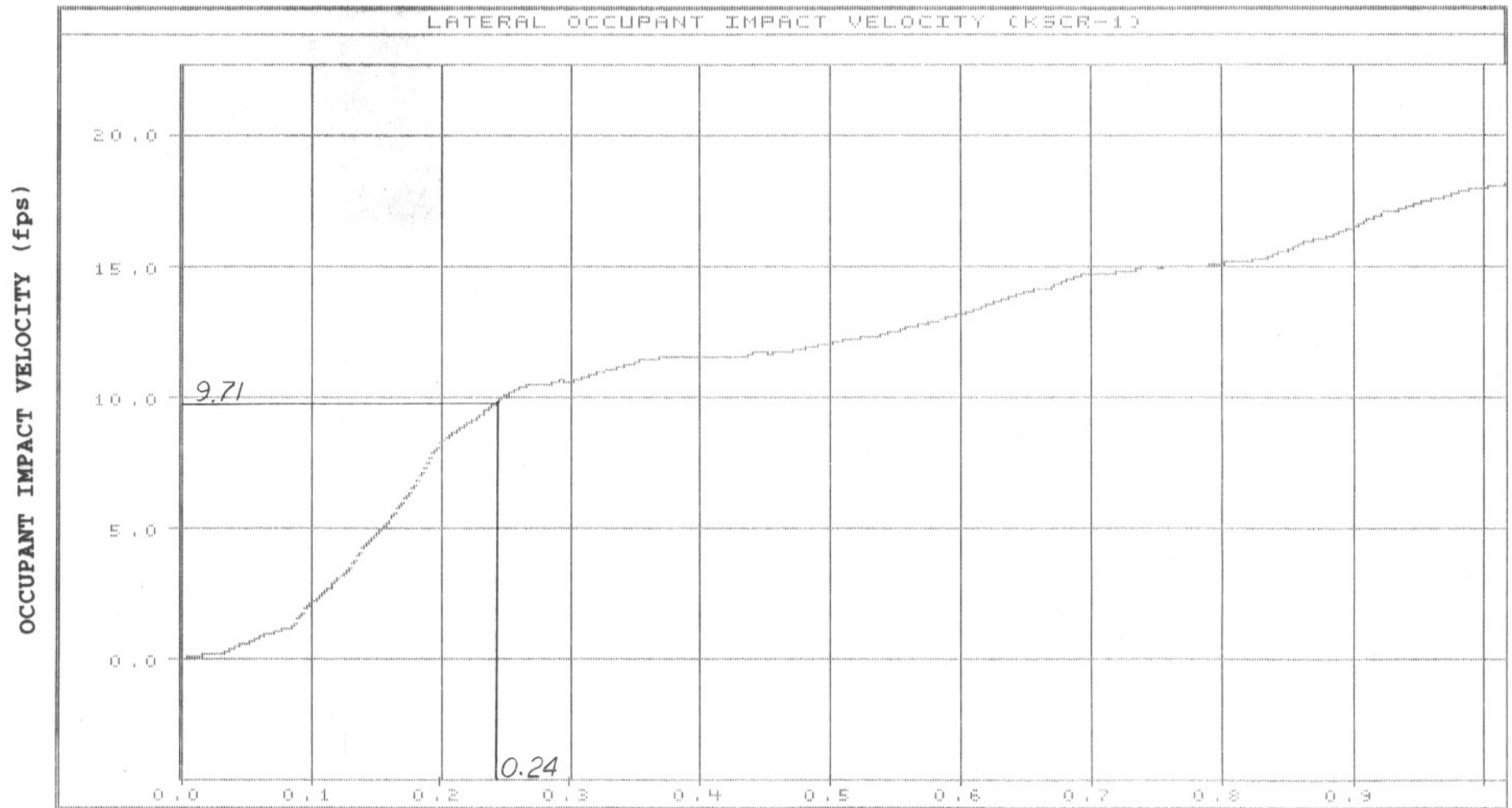

FIGURE C-8. GRAPH OF LATERAL DECELERATION, ACC. #4



$$(\Delta V)^* = (\Delta V) \frac{(V \sin \theta)_{\text{Target}}}{(V \sin \theta)_{\text{Actual}}} = \frac{(9.71)(73.5 \sin 15^\circ)}{(75.71 \sin 15^\circ)}$$

$$(\Delta V)^* = 9.43 \text{ fps}$$

FIGURE C-9. GRAPH OF LATERAL OCCUPANT IMPACT VELOCITY, Acc. #4

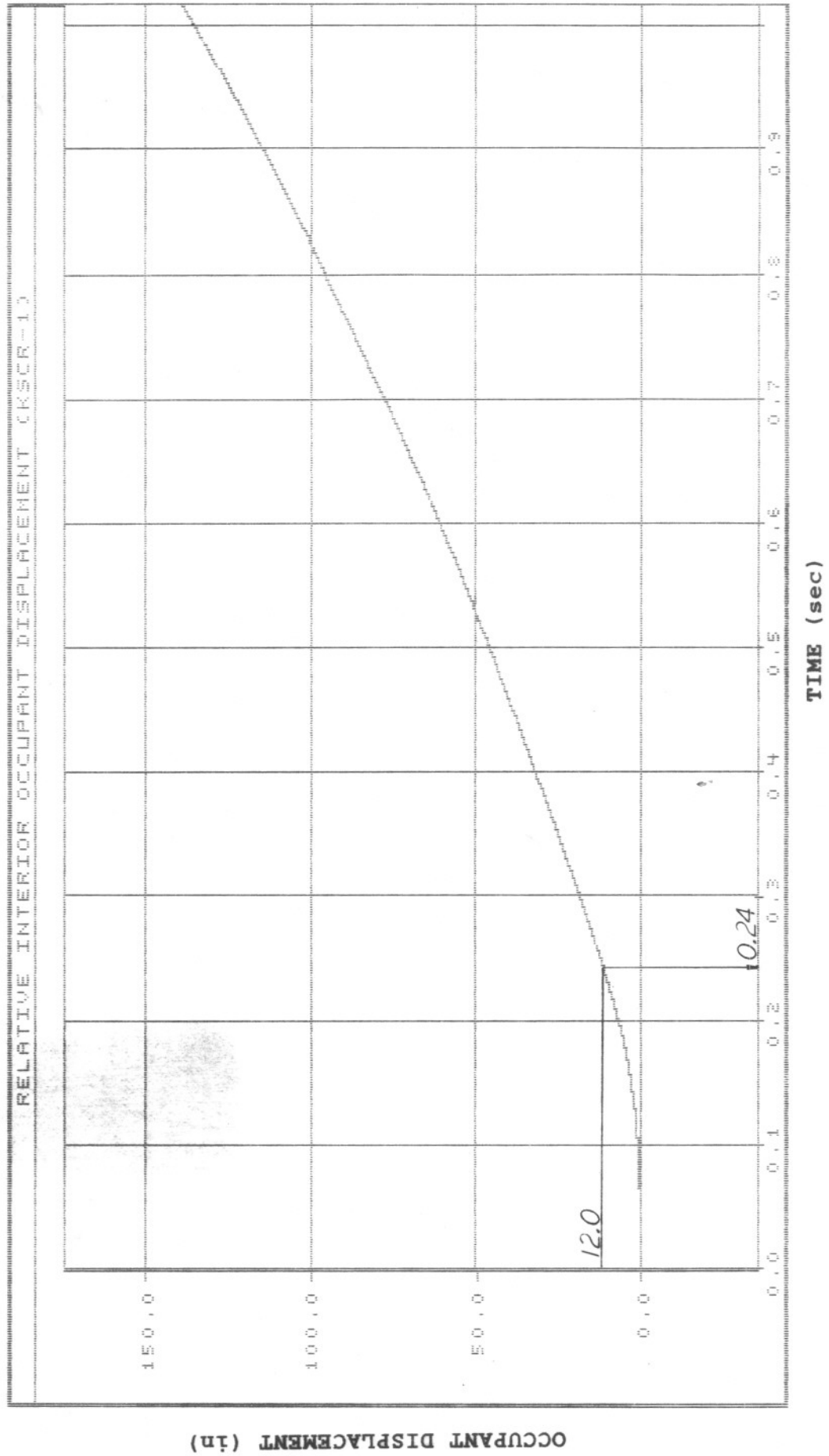

FIGURE C-10. GRAPH OF LATERAL OCCUPANT DISPLACEMENT, ACC. #4

KSCR Report Distribution

Personnel involved with UNL Pooled Fund Testing. For all tests notify: 1) Nebraska representatives, 2) Appropriate state's representatives 3) FHWA Region 7

NEBRASKA

5 ✓ Mr. Dalyce Ronnau
Research and Tests Engineer
Nebraska DOR
P. O. Box 94759
Lincoln, NE 68509

Telephone (402) 479-4756
FAX (402) 479-3975

2 ✓ Mr. Milo Cress
Bridge Engineer
FHWA - Nebraska Division
100 Centennial Mall - Room 220
Lincoln NE 68508-3851

Telephone (402) 437-5521
FAX (402) 437-4146

MISSOURI

2 ✓ Mr. Dan Davidson
Design Division
Missouri HTD
P. O. Box 270
Jefferson City MO 65102

Telephone (314) 751-4659
FAX (314) 751-6555

Mr. Larry Biedel, Bridge Engr
Mr. Don James, Safety Engineer
FHWA - Missouri Division
P O Box 1787
Jefferson City MO 65102

Telephone (314) 636-7104
FAX (314) 636-9283

FHWA - REGION

5 ✓ Mr. Bill Wendling
FHWA - Region 7
6301 Rockhill Road
P O Box 419715
Kansas City MO 64141

Telephone (816) 926-7421
FAX (816) 926-7879

KANSAS

20 ✓ Mr. Ron Seitz
Design Divison
Kansas DOT
Docking State Office Building
Topeka, KS 66612

Telephone: (913) 296-3890
FAX: (913) 296-6946

✓ Mr. Jeff Smith, Bridge Engineer
Mr. Bob Alva, Safety Engineer
FHWA - Kansas Division
444 SE Quincey
Topeka KS 66683

Telephone (913) 295-2550
FAX (913) 752-2556

IOWA

2 ✓ Mr. Dave Little
Roadway Design
IOWA DOT
826 Lincolnway
Ames IA 50010

Telephone (515) 239-1402
FAX (515) 232-0843

✓ Mr. Bruce Brakke, Bridge Engr
Mr. Jack Latterell, Safety Engr
FHWA - Iowa Division
P O Box 627
Ames IA 50010

Telephone (515) 233-1664
FAX (515) 233-5727

UTAH

✓ Ms. Becky Curtis
Procurement Services
Utah DOT
4501 S 2700 West
Salt Lake City UT 84119

Telephone (801) 965-4067
FAX (816) 965-4338

