

**SGR22a**  
Section A- A

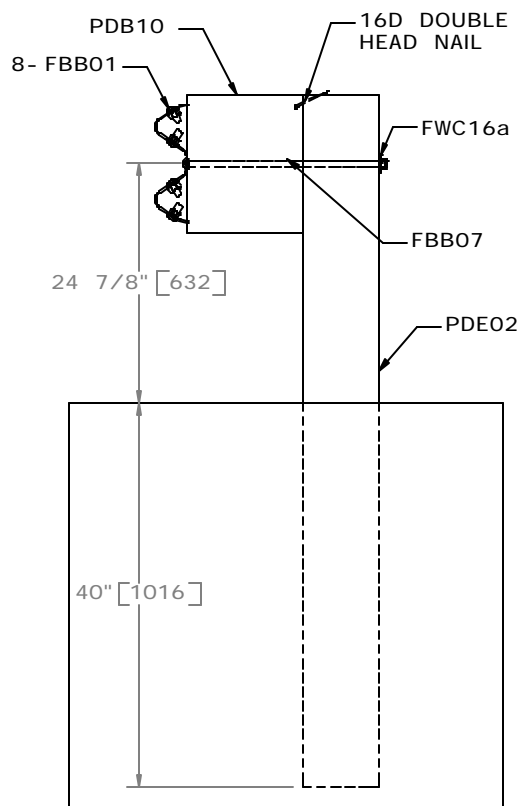

**SGR22b**

**MIDWEST GUARDRAIL SYSTEM WITH 1/4 POST SPACING**



**SGR22a-b**

SHEET NO.	DATE:
1 of 2	04/12/2006

## INTENDED USE

Midwest Guardrail System (MGS) with 1/4 post spacing should be used in locations where a maximum dynamic deflection of 17 1/2" [447] or less is acceptable and where a working width of 35" [889] is provided. MGS should be anchored and terminated using a suitable guardrail end treatment that is approved with a 31" [787] top mounting height. MGS can be used with wide-flange steel posts (PWE06) or timber posts (PDE02).

## COMPONENTS

Unit Length = 12'- 6" [3810]

DESIGNATOR	COMPONENT	SYSTEM	NUMBER
FBB01	Guardrail splice bolts and nuts	a- b	8
FBB06	Guardrail post bolts and nuts	a	8
FBB07	Guardrail post bolts and nuts	b	8
FWC16a	Round washer	b	8
PDB10	MGS timber blackout	b	8
PDB11	W- beam timber blackout	b	8
PDE02	Timber guardrail post	b	8
PWE06	Wide- flange guardrail post	a	8
RWM04	W- beam rail	a- b	1
- - - - -	16D double head nail	a- b	8

## APPROVAL

FHWA Approval Letter [B- 133](#), March 1, 2005.

## REFERENCES

Polivka, K.A., Faller, R.K., Sicking, D.L., Reid, J.D., Rohde, J.R., Holloway, J.C., Bielenberg, R.W., and Kuipers, B.D., Development of the Midwest Guardrail System (MGS) for Standard and Reduced Post Spacing and in Combination with Curbs, Final Report to the Midwest State's Regional Pooled Fund Program, Transportation Research Report No. TRP- 03- 139- 04, Project No. SPR- 3(017)- Years 10, and 12- 13, Project Code: RPPF- 00- 02, 02- 01, and 03- 05, Midwest Roadside Safety Facility, University of Nebraska- Lincoln, September 1, 2004.

Faller, R.K., Polivka, K.A., Kuipers, B.D., Bielenberg, B.W., Reid, J.D., Rohde, J.R., and Sicking, D.L., *Midwest Guardrail System for Standard and Special Applications*, Paper No. 04- 4778, Transportation Research Record No. 1890, Transportation Research Board, National Research Council Washington, D.C., January 2004, pp. 19- 33.

Sicking, D.L., Reid, J.D. and Rohde, J.R., *Development of the Guardrail System*, Transportation Research Record No. 1797, Transportation Research Board, National Research Council, Washington, D.C., November 2002, pp. 44- 52.

## CONTACT INFORMATION

Midwest Roadside Safety Facility  
E527 Nebraska Hall  
Lincoln, NE 68588- 0529  
(402) 472- 0965  
Email: [mwrfsf@unl.edu](mailto:mwrfsf@unl.edu)  
Website: <http://mwrfsf.unl.edu/>



## MIDWEST GUARDRAIL SYSTEM WITH 1/4 POST SPACING

# SGR22a-b



SHEET NO.

DATE:

2 of 2

04/12/2006